

REVIEW ARTICLE



OPEN ACCESS

Received: 25-06-2020

Accepted: 27-08-2020

Published: 10-09-2020

Editor: Dr. Natarajan Gajendran

Citation: Prajapati Y, Patel J, Kamat V (2020) Automatic Generation Control (AGC) operation in a restructured power system under Availability Based Tariff (ABT) mechanism by considering peak hours and off-peak hours. Indian Journal of Science and Technology 13(33): 3400-3408. <https://doi.org/10.17485/IJST/v13i33.1002>

*Corresponding author.

Tel: 9925044099

yrprajapati@bvmengineering.ac.in

Funding: None

Competing Interests: None

Copyright: © 2020 Prajapati et al. This is an open access article distributed under the terms of the [Creative Commons Attribution License](https://creativecommons.org/licenses/by/4.0/), which permits unrestricted use, distribution, and reproduction in any medium, provided the original author and source are credited.

Published By Indian Society for Education and Environment ([iSee](https://www.indjst.org/))

ISSN

Print: 0974-6846

Electronic: 0974-5645

Automatic Generation Control (AGC) operation in a restructured power system under Availability Based Tariff (ABT) mechanism by considering peak hours and off-peak hours

Yogesh Prajapati^{1*}, Jatinkumar Patel², Vithal Kamat³

¹ Electrical Engineering Dept, BVM Engineering College, Vallabh Vidyanagar, India. Tel.: 9925044099

² Electrical Engineering Dept, G H Patel College of Engg. & Tech, Vallabh Vidyanagar, India
³ CEO, Baroda meters limited, Anand, India

Abstract

Objectives: To simulate automatic generation control (AGC) operation in a deregulated power system under availability based tariff (ABT) mechanism to regulate grid frequency during peak and off-peak hours. **Method:** For the simulation, the two areas, an isolated power system with Area1, which has thermal - hydropower plants with two DISCOs, and Area2 having a thermal - thermal power plant with two DISCOs have been considered. DISCO participation matrix (DPM) has been used for the visualization of bilateral contract by distribution companies (DISCOs) in the restructured environment. An AGC operation of two area power system with 10% load variations during peak hour and off-peak hour has been presented for the 24 hours in graphical form. **Findings:** The deviations in the grid frequency and Unscheduled Interchange (UI) charges or deviation settlement mechanism (DSM) rates of ABT due to sudden load changes and renewable power found. The frequent AGC operation of generators against load variation to stabilize the grid frequency is increasing wear and tear losses which finally increases maintenance cost and sometimes tripping of generators. Also, in peak hours and off-peak hours the drastic change in UI charges found during AGC operation so, there is a need to regulate grid frequency from the load side using distributed energy sources. **Novelty:** In proposed work, at the distribution side, Electric vehicle has been considered to regulate grid frequency during peak and off-peak hours. Work has been justified by appropriate data and simulated results.

Keywords: AGC; deregulation; peak hours; offpeak hours; ABT

1 Introduction

An electric power utility has adopted deregulated market practice worldwide and restructuring is going on⁽¹⁾ and reshuffled into GENCOs, TRANSCOs, DISCOs, and ISOs of a power system. DISCOs are authorized to contract with any GENCOs under the supervision of ISO. A lot of ancillary services like voltage control, reactive power control, load balancing, and frequency control has been provided by ISO. Automatic generation control (AGC) is one of the supplementary services. LFC is one of the most important services among these. After deregulation, the various issues concerning load frequency control (LFC) has been discussed for the operation and control of power system⁽²⁾. The LFC or AGC has been realized that researchers have to reformulate the AGC problem in a restructured environment⁽³⁾. A broad investigation with techno-economical aspects of Ancillary Services (AS) in competitive electricity markets with its various types, definition, different contracts, and dispatch method along with RES is presented⁽⁴⁾. AGC is one of the ancillary services at the generating station.

Also, Generator has its capability to regulate frequency, but the regulation capacity of the generator is limited to slow-moving changes in power frequency. If generators are taking part in AGC operation repeatedly, the operational effectiveness of the generator will diminish and it leads to enlarge in generation cost, further wear and tear of the generator, which will fall out in certainly incur high maintenance costs. So due to the deliberate response of the governor, it is not competent to pay off sudden load changes for a stretched time⁽⁵⁾. Besides, today the grid is a smart grid and grid associated solar and wind power plant exists in many places. The natural history of these renewable sources is also unpredictable with esteem to weather conditions. So the power which is fed by these sources also creates deviations in frequency which further adds into the deviations owing to the load⁽⁶⁾. The ABT mechanism with different tariff rates during peak hours and off-peak hours was introduced to regulate the grid frequency and to operate the power system in a disciplined mode⁽⁷⁾. A novel control scheme is also presented by comparing the error signal of marginal cost and error signal of frequency cost⁽⁸⁾.

But, there are lots of issues to regulate frequency from the generator side such as an increase in the tear and wear of the generating unit. So it may be a better option to regulate grid frequency from the demand side, so generators will not disturb. It has been trying to show that there is a need to work out at the distribution side to regulate the grid frequency instead of controlling generators at a generating station which helps in AGC operation. The use of Electrical Vehicle for the load frequency control problem and the service can be one of the ancillary services of AGC^(9,10). Also, the need for large energy storage for on-grid and off-grid applications has been discussed^(11,12).

To realize the frequency deviations during peak and off-peak hours owed to load oscillation, the power system has been synthetically cut off in two areas which contain two GENCOs in each and its existing distribution companies. The operation of AGC with changes in the UI (DSM) charges under peak hours and off-peak hours are presented. The UI changes can be minimized during peak hours and off-peak hours⁽¹³⁾.

2 Description of two area restructured power system

In the DPM matrix, the number of rows equals the number of GENCOs and the number of columns equals the number of DISCOs in the system. The matrix shows the total load power contracted by DISCOs with respective GENCOs; hence is the name "DISCO Participation Matrix". The DISCO participation matrix (DPM) represents the contract of any DISCO with any GENCO under the supervision of ISO⁽⁵⁾.

The visualization of a bilateral contract in an interconnected power system of Gujarat has been assumed and synthetically divided into Area1 and Area2 as shown in [Figure 1](#). Area1 consists of two generating companies GENCO1 (Thermal Unit) and GENCO2 (Hydro unit) with DISCO1 and DISCO2. Similarly, Area2 consists of two generating companies GENCO3 (Thermal Unit) and GENCO4 (Thermal Unit) with two distribution companies DISCO3 and DISCO4. Two area power systems in a deregulated environment are shown in [Figure 1](#). The corresponding DPM is given as follows.

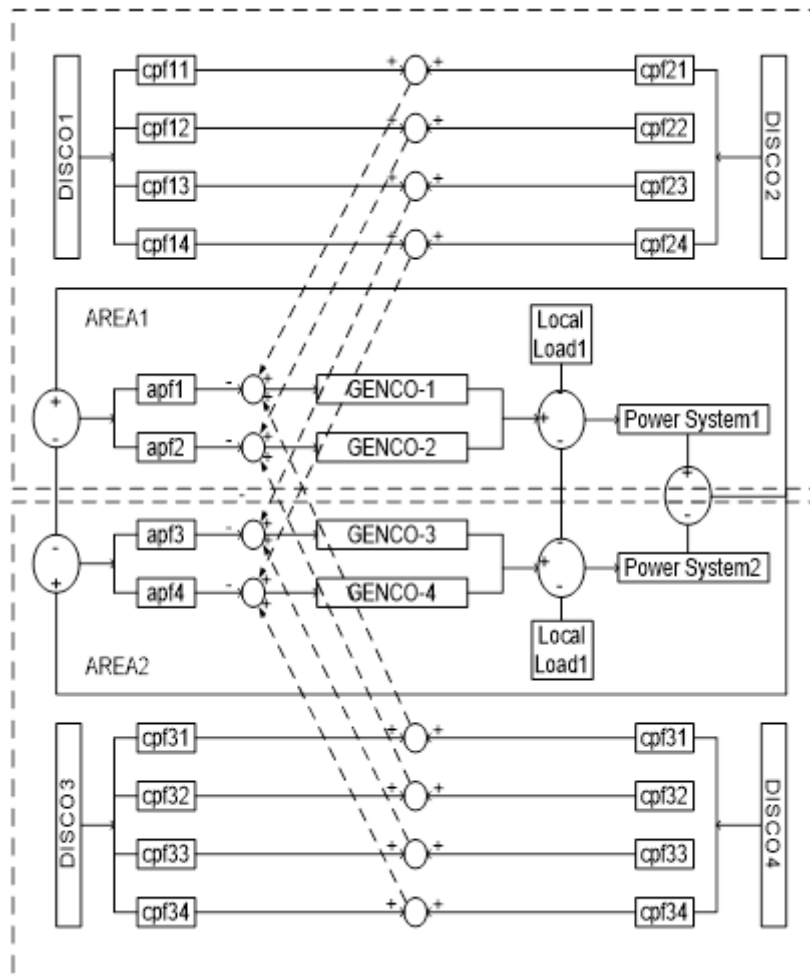

Fig 1. Block diagram representation two areas restructured power system

$$DPM = \begin{bmatrix} cpf_{11} & cpf_{12} & cpf_{13} & cpf_{14} \\ cpf_{21} & cpf_{22} & cpf_{23} & cpf_{24} \\ cpf_{31} & cpf_{32} & cpf_{33} & cpf_{34} \\ cpf_{41} & cpf_{42} & cpf_{43} & cpf_{44} \end{bmatrix} \tag{1}$$

Where, $\sum_i cpf_{ij} = 1$, *cpf* refers to "Contract Participation Factor", which transmits information to respective GENCO to follow the demanded load by the DISCO. It is noted the diagonal elements correspond to the local demand and off-diagonal elements correspond to the DISCOs demand in one area to another area GENCOs. Suppose that DISCO3 demands 150 MW powers, out of which 30 MW is demanded from DISCO1, 45 MW from DISCO2, 60 MW from DISCO3, and 15 MW from DISCO4. Then column 3 entries in (1) are easily defined as in (2). The following mathematical formulas have been used for the simulation of the two areas restructured power system [6].

$$\begin{aligned} cpf_{13} &= \frac{30}{150} = 0.2, & cpf_{23} &= \frac{45}{150} = 0.3 \\ cpf_{33} &= \frac{60}{150} = 0.4, & cpf_{43} &= \frac{15}{150} = 0.1 \end{aligned} \tag{2}$$

The contracted power supplied by *i*th GENCO is given in (3).

$$\Delta P_{gi} = \sum_{j=1}^{DISCO 4} cpf_{ij} \Delta P_{Lj} \tag{3}$$

Where, ΔP_{Lj} is the total demand for DISCO_j (4).

$$\begin{aligned} \Delta P_{L1,LO C} &= \Delta P_1 + \Delta P_2 \\ \Delta P_{L2,LO C} &= \Delta P_{31} + \Delta P_4 \end{aligned} \tag{4}$$

The actual and scheduled steady-state power flow through the tie-line is given in (5). The Actual tie-line flow is given by (6) and the error in the tie-line flow is given by (7).

$$\Delta P_{\text{tiel-2,scheduled}} = (\text{denanbf DISCOsinareall fromGENCOsinareal}) - (\text{denanbf DISCOsinareal fromGENCOsinareall})$$

$$\Delta P_{\text{tiel-2,scheduled}} = \sum_{i=1}^2 \sum_{j=3}^4 cpf_{ij} \Delta P_{Lj} - \sum_{j=3}^4 \sum_{i=1}^2 cpf_{ij} \Delta P_{Lj} \tag{5}$$

$$\Delta P_{\text{tiel-2,actual}} = \left(\frac{2\pi T_{12}}{s} \right) (\Delta F_1 - \Delta F_2) \tag{6}$$

$$\Delta P_{\text{tiel-2,error}} = \Delta P_{\text{tiel-2,actual}} - \Delta P_{\text{tiel-2,scheduled}} \tag{7}$$

The error signal (7) is used to generate the respective area control error (ACE) signals as in the traditional scenario.

$$\begin{aligned} ACE_1 &= B_1 \Delta f_1 + \Delta P_{\text{tiel-2,error}} \\ ACE_2 &= B_2 \Delta f_2 + a_{12} \Delta P_{\text{tiel-2,error}} \end{aligned} \tag{8}$$

Where P_{r1} and P_{r2} are rated capacities of area 1 and area 2.

3 Availability Based Tariff (ABT)

3.1 Capacity Charge (Fixed Charge)

It is linked to the availability of the plant like its capability to deliver MWs on a day to day basis.

An amount per year paid to the generating company depends on the average availability of the plant against the fixed cost. Scheme named availability because the generating company will be paid higher if the average actual availability of the plant is higher than actual availability and payment will lower if an average actual availability achieved is lower.

3.2 Energy Charge (Variable Charges)

For the day the fuel cost of the power plant for generating energy is variable, so it is according to the scheduled generation instead of actual generation. So it is a variable charge.

3.3 DSM/UI charge

It is a frequency linked component. UI rates will be small when the frequency is above 50 Hz (Indian frequency) and high when frequency below 50 Hz. ABT meters are recording deviations from the schedule in 15-minute time blocks if any deviations. The user has to pay the UI charge in case of over drawl. We have peak hours and off-peak hours during a day. UI charge is high during low-frequency condition, which controls the over drawl and low during the high-frequency condition, means surplus energy in the grid.

4 Modeling of Frequency-UI (DSM) price block

The shape of the UI price vs. frequency curve has been a subject of much debate among the sector participants. Regular modifications have been done in the shape of the UI curve since it was introduced in 2000. The modifications have been ordered by the Central Electricity Regulatory Commission (CERC), to meet the stated objectives of the ABT mechanism⁽¹⁴⁾. Initially, the

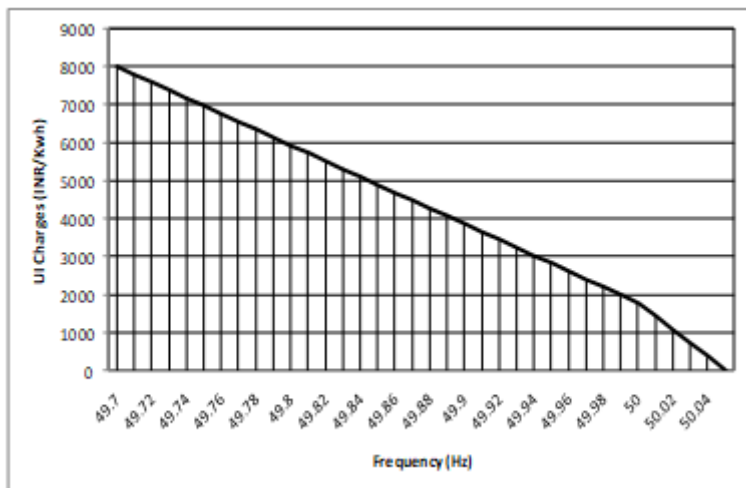

Fig 2. UI price vs frequency chart (CERC, 2016)

frequency range in which UI prices vary was set between 49.0 and 50.5 Hz (CERC, 2000). In 2016, CERC has come up with the latest regulations (CERC, 2016) which set the frequency range between 49.7 and 50.05 Hz^(15,16). Charges for deviation for each 0.01 Hz step is equivalent to 35.60 Paise/Kwh in the frequency range of 50.05-50.00 Hz, and 20.84 paise/Kwh in the frequency range below 50 Hz to below 49.7 Hz. This curve is shown in Figure 2 . The maximum price is set by CERC to accommodate the highest price generation in the system.

The relation between UI price and frequency deviation has been implemented using an embedded MATLAB function block in MATLAB/Simulink. The code for the block is given below.

```

if frequency<=49.7
Price=8032;
elseif frequency<=50
Price=1780+20856*(50-frequency);
elseif frequency<=50.05
Price=35600*(50.05-frequency);
else
Price=0;
End
    
```

5 Results

For the simulation of the two areas restructured power system with 24 hours of operation is considered (Figure 1). From the morning 6 AM to 11 AM and in the evening from 6 pm to 11 pm are considered as peak hours. Midnight 11 pm to a morning at 6 am and morning 11 am to evening 6 PM are assumed as off-peak hours. The results of changes in power and area frequency at generating stations are represented in Figures 3 and 4 due to 10% changes in the load. Figures 5 and 6 shows the respective UI charges against changes in the frequency. Figure 7 shows the power follow on tie-line to meet the load changes. It is assumed that DISCOs in area1 demands 3000 MW power and DISCOs in area2 demands 2000 MW power of respective GENCOs. During the peak hour operation of the power system DISCOs in the area1 which are DISCO1 and DISCO3 demands 225 MW each and DISCOs of area2 which are DISCO2 and DISCO4 demands for 125 MW each and during an off-peak hour operation of power system DISCOs in area1 which are DISCO1 and DISCO3 demands 150 MW each and DISCOs of area2 which are DISCO2 and DISCO4 demands for 50 MW each. During peak hours 6 Hrs to 11 Hrs and 18 Hrs to 23 Hrs 10% change in load (450 MW in area1 and 150 MW in area2) and during off-peak hours 10% change in load (300 MW in area1 and 200 MW in area2) has been considered in both areas for better visualization of price based operation of the power system. An area participation factor (apfs) and DPM matrix are assumed as follows. Change in generated power has been calculated on an average basis for both areas for peak and off-peak hours of operations of the power system are given as below,

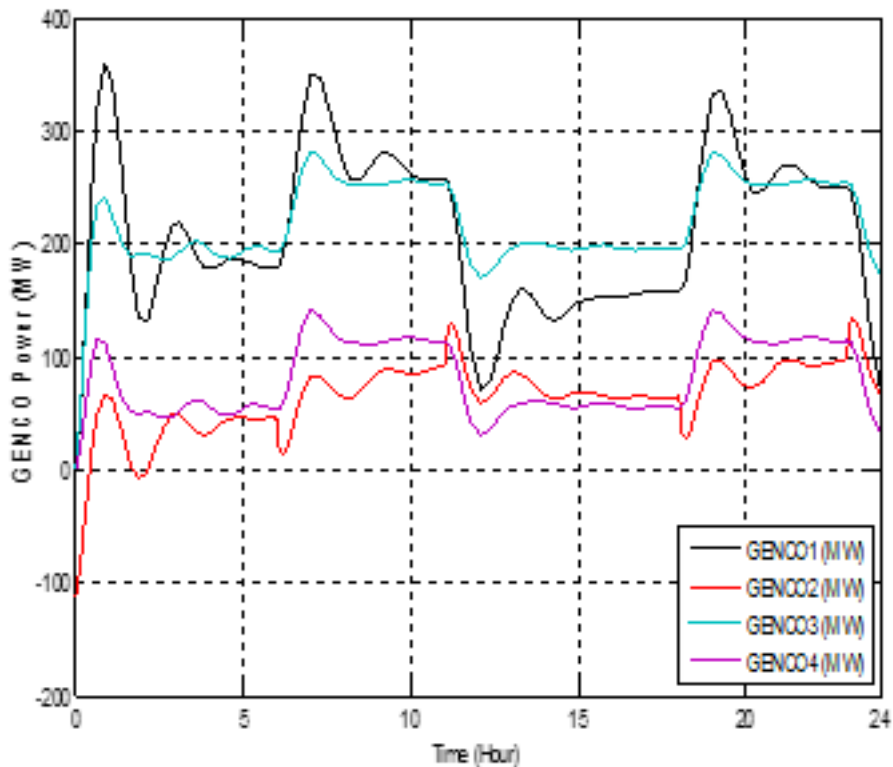

Fig 3. GENCO Power (MW)

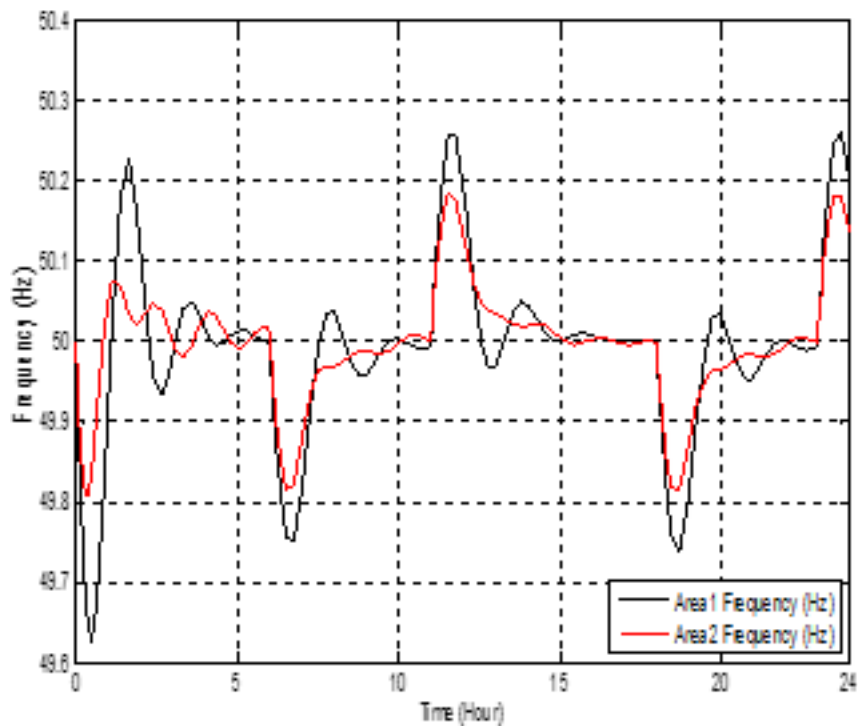

Fig 4. Frequency (Hz)

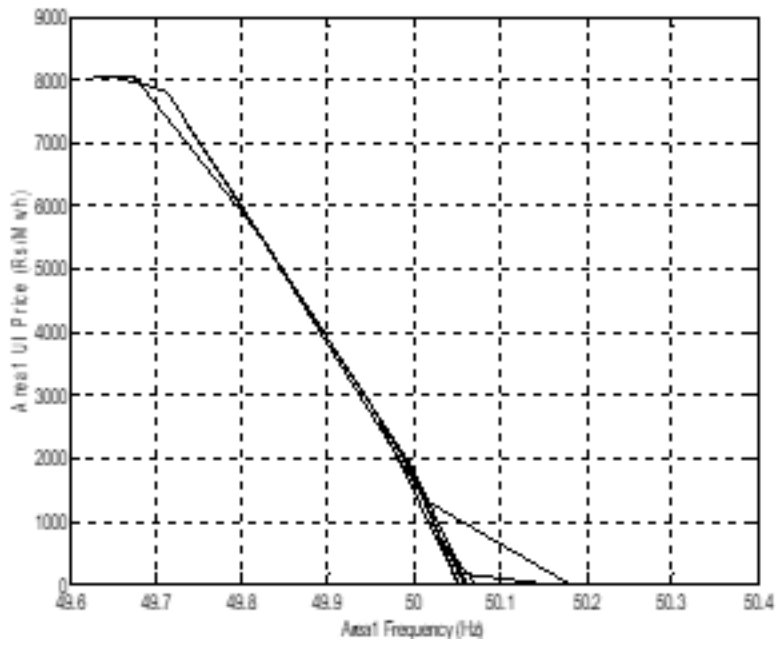

Fig 5. Area 1 UI Curve

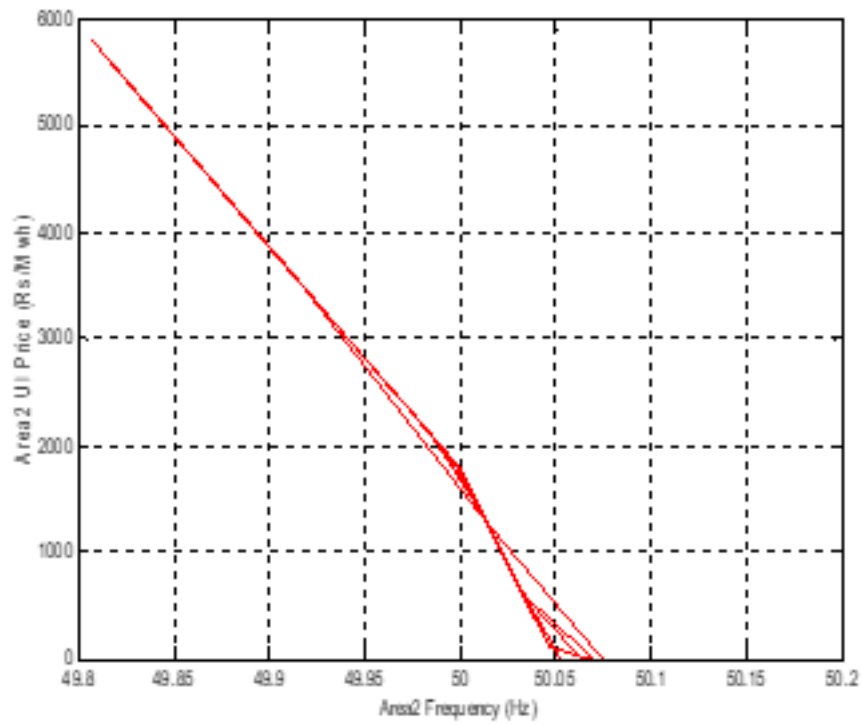

Fig 6. Area 2 UI Curve

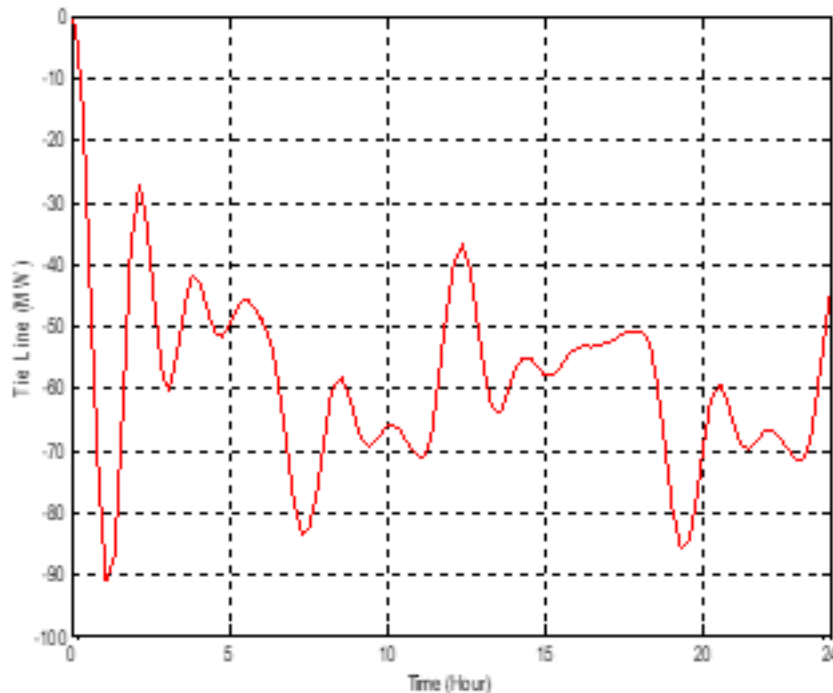

Fig 7. Tie Line Power (MW)

$$apf_1 = 0.75, apf_2 = 1 - apf_1 = 0.25, apf_3 = 0.5, apf_4 = 1 - apf_3 = 0.5$$

$$DPM = \begin{bmatrix} 0.5 & 0.25 & 0 & 0.3 \\ 0.2 & 0.25 & 0 & 0 \\ 0 & 0.25 & 1 & 0.7 \\ 0.3 & 0.25 & 0 & 0 \end{bmatrix} \tag{9}$$

6 Conclusion

Presently, in the restructured power system, many generating companies are operating under the AGC approach to follow the demand due to the sudden load variation frequency deviations. A Bilateral Contracts with Poolco based market exist between DISCOs of one control area and GENCOs of another control area. The "DISCO" Participation matrix helps to replicate the contracts. As per the CERC 2016, deviation settlement charges (erstwhile UI) have been observed in a restructured power system under the different contracts that due to the uncertainty of power supply from renewable sources to a stable grid, demand and fluctuations. The fluctuation causes frequency variations and deviation settlement for off-peak and peak hours price which reflects in the proposed work. Our work able to provide effective solutions for reducing maintenance and wear and tear cost in generating stations.

Appendix

Pr1=3400 MW, Pr2=2600 MW, PL1=3000 MW, PL2= 2000 MW, F=50 Hz, H1=H2=5, D1=0.02, D2=0.013, Tg1=Tg2=0.08, Tt1=Tt2= 0.3, Tr1=Tr2=10, Kr=0.5, B1=B2=0.425, R1=R2=2.4, T12=0.545, Kd=1.2, Kp=2.4, Ki=4.5, Tw=1, Tp1=10.

References

- 1) Christie RD, Bose A. Load frequency control issues in power system operations after deregulation. *IEEE Transactions on Power Systems*. 1996;11(3):1191–1200. Available from: <https://dx.doi.org/10.1109/59.535590>.

- 2) Abraham RJ, Das D, Patra A. Load following in a bilateral market with local controllers. *International Journal of Electrical Power & Energy Systems*. 2011;33:1648–1657. Available from: <https://dx.doi.org/10.1016/j.ijepes.2011.06.033>.
- 3) Kumar P, Kazmi AS, Yasmeen N. Comparative study of automatic generation control in traditional and deregulated power environment. *World Journal of Modelling and Simulation*. 2010;6(3):189–208. Available from: <http://www.worldacademicunion.com/journal/1746-7233WJMS/wjmsvol06no03paper03.pdf>.
- 4) Banshwar A, Sharma NK, Sood YR, Shrivastava R. International experience of technical and economic aspects of ancillary services in the deregulated power industry: Lessons for emerging BRIC electricity markets. *Renewable and Sustainable Energy Reviews*. 2018;90:774–801. Available from: <https://doi.org/10.1016/j.rser.2018.03.085>.
- 5) Donde V, Pai MA, Hiskens IA. Simulation and optimization in an AGC system after deregulation. *IEEE Transactions on Power Systems*. 2001;16(3):481–489. Available from: <https://dx.doi.org/10.1109/59.932285>.
- 6) Prajapati YR, Kamat VN, Patel JJ, Parekh BR. Impact of Grid Connected Solar Power on Load Frequency Control. In: and others, editor. *Restructured Power System. i-Pact*. 2017. Available from: <https://ieeexplore.ieee.org/document/8245122>.
- 7) Gupta M, Gupta S, Thakur T. Implementation of new electricity regulatory norms for deviation settlement mechanism: A case study of India. *Cogent Engineering*. 2019;6(1). Available from: <https://dx.doi.org/10.1080/23311916.2019.1623152>.
- 8) Hasan N, Ahmad S. ABT Based Load Frequency Control of Interconnected Power System. *Electric Power Components and Systems*. 2016;44:853–863. Available from: <https://dx.doi.org/10.1080/15325008.2016.1138160>.
- 9) Liu H, Hu Z, Song Y, Wang J, Xie X. Vehicle-to-Grid Control for Supplementary Frequency Regulation Considering Charging Demands. *IEEE Transactions on Power Systems*. 2015;30(6):3110–3119. Available from: <https://dx.doi.org/10.1109/tpwrs.2014.2382979>.
- 10) Xie P, Qian B, Shi D, Chen J, Zhu L. Supplementary automatic generation control using electric vehicle battery swapping stations. *IEEE PESGM*. 2013.
- 11) Pan X, Xu H, Song J, Lu C. Capacity Optimization of Battery Energy Storage Systems for Frequency Regulation. In: and others, editor. *IEEE International Conference on CASE*; vol. 10 of 4. 2015; p. 1107–1116. Available from: <https://ieeexplore.ieee.org/document/7436545>.
- 12) Faruk A, Bhuiyan A, Yazdani. Energy storage technologies for grid-connected and off-grid power system applications. *IEEE EPEC*. 2013. Available from: <https://doi.org/10.1109/EPEC.2012.6474970>.
- 13) Prajapati RY, Kamat NV, Patel J. Load Frequency Control Under Restructured Power System Using Electrical Vehicle as Distributed Energy Source. *Journal of The Institution of Engineers (India): Series B*. 2020;101(4):379–387. Available from: <https://dx.doi.org/10.1007/s40031-020-00458-5>.
- 14) Murali V, Sudha KR. Price based fuzzy automatic generation control for Indian tariff system. *Energy Systems*. 2019;10(1):231–246. Available from: <https://dx.doi.org/10.1007/s12667-018-0273-0>.
- 15) Pujara A, Pujara J, Velhal G, Bakre SM, Muralidhara V, Muralidhara. Load Frequency Control Under Availability Based Tariff Environment Using Client-Server Communication: A Case. *International journal of scientific & technology research*. 2019;8(10).
- 16) India Report. 2016. Available from: http://www.cercind.gov.in/2017/annual_report/ANE.pdf.