

# A Novel Tuning Method of PID Controller for a BLDC Motor based on Segmentation of Firefly Algorithm

Aqeel S. Jaber\*

Faculty of Engineering of Electrical Power Techniques, Al-Mamon University College, Baghdad, Iraq;  
Aqe77el@yahoo.com

## Abstract

**Background/Objectives:** The efficient and robustness of motors speed control are ones of the big challenges in electrical machines drive science. The control of PMDC motor represented a common part of those challenges. **Methods/Statistical Analysis:** This paper introduces a novel optimizing method to calculate the controller PID parameters in order to get a high performance DC motor. A modification of original firefly optimization method has been done and named as firefly-segmentation method. The new method is based on a combination of firefly algorithm and dividing the searching method as segment by segment. Four segments for KP and two for KI was selected as initial values of PID parameters. **Findings:** The performance of the new method is judged via MATLAB simulations using typical BLDC motor with multi-known speeds. The overshoot and settling time of obtained parameters results show that the proposed optimizing method is superior controller comparing with classical PSO and firefly methods. **Application/Improvements:** A robustness of speed response is expected through the new optimization method with respect to conventional methods especially in high speed.

**Keywords:** Firefly, Optimization, PMDC Motor, PID Controller, Speed Control

## 1. Introduction

The improvement in energy efficiency of machine controllers has been one of the most challenging tasks in new generation electrical industry over the last decade<sup>1,2</sup>. Economic constraints and new standards by international criteria are putting increasingly stringent requirements on different electrical systems. New generation equipment, components and systems' controllers must have higher efficiency with high robustness. Wide range of applications of brushless DC motor are replacing such as automotive, household appliances, aviation, and control of Mach scale of Swash plateless rotor. A very robust with efficient motor operation required to these applications. In general the characteristics and curves of PMCD motors are more similar to a separately excited DC motor<sup>3</sup>.

Many analytical design schemes of BLDC motors controller have been proposed in the last decades. Such as the conventional back-EMF sensing method<sup>4</sup>. In the

beginning of the current century, a multispeed transmission units was installed in order to improve the motor controller<sup>5</sup>. Later, a method was presented based on state observer<sup>6-8</sup>. Also many intelligent methods have been done to tune the controller parameters using Particle Swarm Optimization (PSO)<sup>9</sup>, classical firefly optimization, and Bacterial Foraging Algorithm (BFA)<sup>10</sup>. A serious drawback of classical systems, for example the needs for several isolated power supplies which increases the complexity or external noise.

In order to improve the previous methods of BLDC controllers, a novel method depend on dividing the initial range of firefly optimization method have been suggested in this paper. The desired speed efficiently and perfectly tracked by using the segmentation of the firefly initial range according to impact of the controller parameter. The simulation results of tuning the control parameters show excellent results in term of signal analysis using MATLAB compared with PSO and classical firefly algorithms.

\*Author for correspondence

## 2. Theoretical Background

### 2.1 BLDC Motors Model

Generally the working principles of an induction motors share some similarities with brushed DC motors<sup>11-13</sup>. Two important parts in PLDC machines, first: is the rotating part, and second: is stationary part (rotor and stator). The stator may be design as inner or outer rotor as shown in Figure 1 these methods called slotted and slot less respectively<sup>14</sup>.

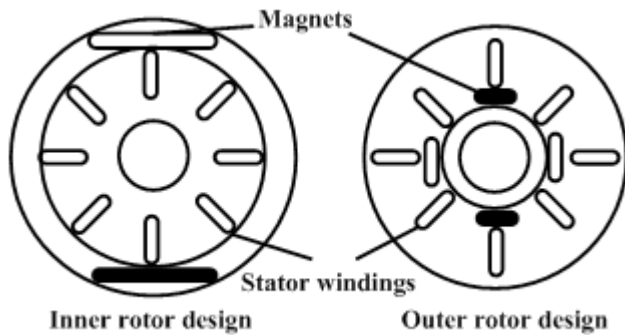

Figure 1. Slotted and slot-less stators.

Generally the mathematical model of BLDC motor can be presented in the following equations

$$V_{1s} = i_{1s}R_s + L_{11} \frac{di_1}{dt} + M_{12} \frac{di_2}{dt} + M_{13} \frac{di_3}{dt} + e_{1s} \quad (1)$$

$$V_{2s} = i_{2s}R_s + L_{22} \frac{di_2}{dt} + M_{21} \frac{di_1}{dt} + M_{23} \frac{di_3}{dt} + e_{2s} \quad (2)$$

$$V_{3s} = i_{3s}R_s + L_{33} \frac{di_3}{dt} + M_{31} \frac{di_1}{dt} + M_{32} \frac{di_2}{dt} + e_{3s} \quad (3)$$

Where :-

$R_s$  is Stator resistance per phase, assuming equal resistances in each phase

$i_1, i_2, i_3$  are stator currents in each phase

$L_{11}, L_{22}, L_{33}$  are stator self-inductances in each phase

$M_{12}, M_{21}, M_{13}, M_{31}, M_{23}, M_{32}$  are mutual inductance of the stator phases and the rotor magnet

$e_{1s}, e_{2s}, e_{3s}$  are induced EMF or back EMF in each phase.

The simulation diagram of BLCM with the controller is shown in Figure 2<sup>15</sup>.

The general block diagram of a BLDC motor control system is shown in Figure 3<sup>16</sup>.

The four main parts of the BLDC control system are the power converter, controller, sensors and motor. The power converter is a three phase power semiconduc-

tor bridge. The main function of the power converter is to transform power from the DC source to AC so the motor can convert electrical energy to mechanical energy. The sensor is used to determine the rotor position, and it sends this information to the controller.

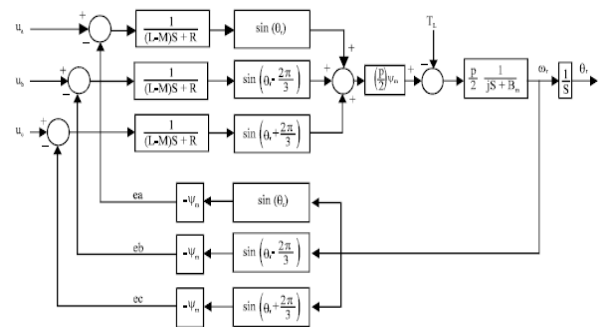

Figure 2. BLCM Simulink diagram.

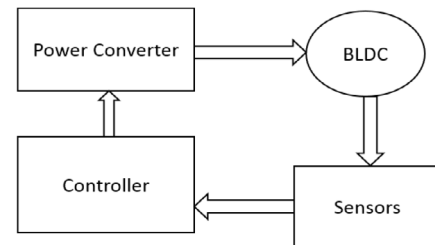

Figure 3. BLDC motor system control.

### 2.1 Classical Firefly Algorithm

In<sup>17</sup> introduced the firefly algorithm as a nature inspired algorithm that derives from the characteristics of fireflies. Many baselines are considered in this optimizing algorithm. First; all of the fireflies can be male or female, so that a firefly will be attractive to any other firefly without taking of the gender as an effectiveness factor. Second; the attractiveness is directly proportional to the amount of brightness of firefly which flickering a light<sup>17</sup>. Also, their amount of the brightness decreases as the distance between the fireflies increases<sup>17</sup>. Each population has no brightest firefly cause to moving of fireflies randomly within the initial range. The objective function (normally minimum or maximum) is calculating or determining the brightness of each firefly. The classical firefly algorithm is shown in Figure 4.

## 3. Proposed Method

There are many requirements to find a new technique to increase the accuracy of firefly optimizing method,

*Firefly Algorithm*

Objective function  $f(x) = ITAE$

Light intensity  $I_i$  at  $X_i$  is determined by  $f(X_i)$

Define light absorption coefficient  $\tau$

**While** ( $t < \text{Max Generation}$ )

**For**  $i = 1 : n$  all  $n$  fireflies

**For**  $j = 1 : i$  all  $n$  fireflies

if ( $I_i > I_j$ ), Move firefly  $i$  toward  $j$  in  $d$ -dimension; **end**

Attractiveness varies with distance  $r$  via  $\exp[-\tau r]$

**end For**  $j$

**end For**  $i$

Rank the fireflies and find the current best

**end while**

Post process results and visualization

**Figure 4.** Firefly algorithm.

because of the indiscriminately of this to estimate a good PID controller parameter, specially, in high order control, which existing multi-optimal parameters. The proposed method depends on dividing of firefly particles to multi-group searching on local optimal point, and known as segments. Each segment working as an initial range of firefly algorithm to find the local point as shown in Figure 5. The points 1, 2 and 3 are representing the best points for each group; also point 3 is representing the global point. The optimal separated positions of the fireflies and the optimal initial range of the new main firefly searching group must be change to estimate the optimal new group as follows;

$$\text{Segment length} = \text{initial limits} \frac{\text{no. of Segments}}{\text{no}} \quad (4)$$

Hence;

$$\text{optimal segment} = \text{optimal } S \mp \text{segment} \frac{\text{length}}{2} \quad (5)$$

Where, optimal S is represented the optimal value of first optimization search. The number of segment is proportional directly with the parameter impact on the fitness. The segmentation may give a direct to the optimal group, which give new boundaries of parameters range with single global point. Also number of segment can increase in case of the wide range of initial value. The searching of firefly in the optimal group gives a chance to get more accurate controller parameters in searching

algorithm. Figure 6 illustrated flowchart of procedure segmentation method.

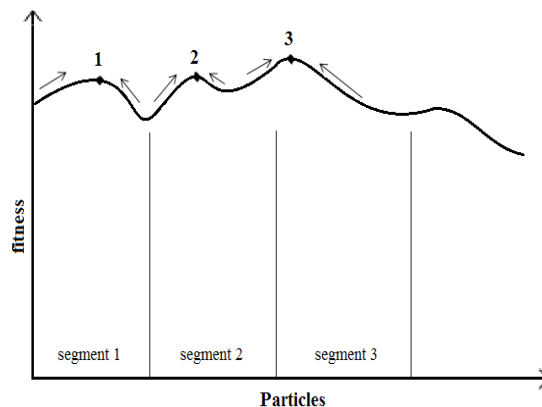

**Figure 5.** Local points of each segment.

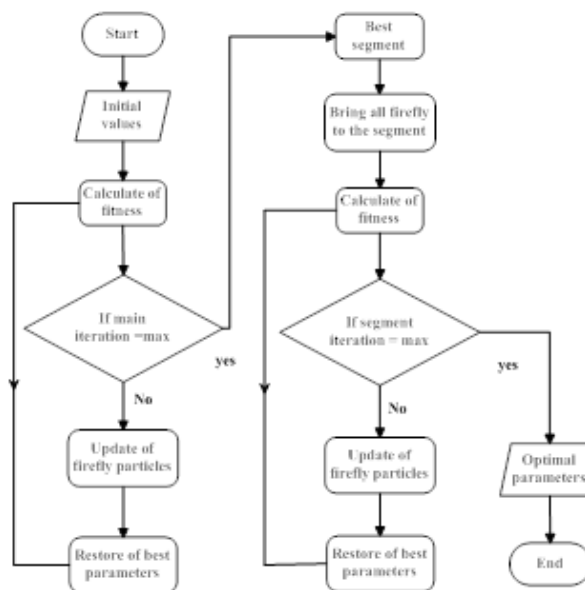

**Figure 6.** Firefly segmentation method.

## 4. Simulink Result

The model of Figure 2 was simulated using MATLAB/SIMULINK in order to exam the proposed method. a three phase BLDC motor with parameters as shown in Table1 was tested and in this paper. The Simulink model consists of an inner current control loop and an outer speed control loop. The speed control was implemented using PID controller and tuned using the three types of optimizing methods. PSO, classical firefly and the proposed method. The motor parameters are listed in Table 1.

**Table 1.** Motor characteristics

Rated power	Rated voltage	Rated speed	Rated torque	Rated current	No. poles
0.5 hp	160 V	4000 rpm	0.89 Nm	17.35 A	4

**Table 2.** Step response

Speed (rpm)	PSO		Classical firefly		Firefly segmentation	
	MP%	Ts(ms)	MP%	Ts(ms)	MP%	Ts(ms)
1000	43.5	15.3	44.3	15.83	38.9	15.2
2000	19.1	15.51	20.4	16.22	17.1	15.50
3000	5.4	15.77	5.6	16.41	4.8	15.79
4000	1.9	16.83	2.3	16.93	1.5	16.97

Table 2 shows the performance of the system using PID, and tuned by using the three methods reference speed of 1000 to 4000 rpm in loaded condition. The Settling Time (TS) and the peak overshoot (MP) were taken as a comparison points to analyze the results. The results show that overcome of the proposed searching method with respect to both of PSO and classical firefly in terms of peak overshoot. That table also show that the setting time of the proposed method in cases of all speed values are 15.2, 15.50, 15.79 and 16.97 respectively, but PSO are 15.3, 15.51, 15.77, 16.83 respectively. The cases show that not all the values of settling time is better in proposed searching method, especially in rated speed. The number of groups was selected as shown in Table 3.

**Table 3.** Selected segments

Parameter	KP	KI	KD
Segment No.	4	2	1

The main FA parameters are set to the optimal settings  $\beta_0 = 0.2$ ,  $\gamma = 1.0$ ,  $\alpha = 0.2$  and the number of fireflies = 20, number of iterations = 100. The bird step = 30,  $c_1 = 1.5$ ,  $c_2 = 1.5$ , and  $\omega = 0.6$ . The boundaries of PID parameters for optimal search are as follows:

$$0.001 < K_p < 50, 0.001 < K_i < 50, \text{ and } 0.001 < K_d < 50.$$

ITAE equation was taken in order to determine the characteristics of the controlled signals.

$$ITAE = \sum_{j=1}^2 \sum_{i=1}^2 \left( \int_0^{100sec} |\Delta f_i^j| t dt \right) \tag{6}$$

## 5. Conclusion

DC motors can be replaced constantly by BLDC many applications especially in low power machines. Fans,

blowers, pumps, and steering wheel are once of this applications. A typical BLDC behaves as a PM DC motor with linear speed vs. torque characteristics where the speed decreases as the load increases. In this research, a novel algorithm of firefly depends on segmentation to the classical method has been suggested and studied for control a BLDC motor. Parameters of PID controller have been tuned using three methods. The segmentation method has been compared with the two methods, which are classical firefly and PSO optimization methods for results verification, a three different speed values are also been suggested. The simulation results prove that the PID which given by the proposed method is better performance and speed response especially in peak overshoot. The International Conference on Fluids and Chemical Engineering (FluidsChE 2017) is the second in series with complete information on the official website<sup>18</sup> and organized by The Center of Excellence for Advanced Research in Fluid Flow (CARIFF)<sup>19</sup>. The publications on chemical engineering allied fields have been published as a special note in volume 320. Host being University Malaysia Pahang<sup>21</sup> is the parent governing body for this conference.

## 6. References

- Rashag HF, Koh SP, Abdalla AN, Tan NML, Chong KH. Modified direct torque control using algorithm control of stator flux estimation and space vector modulation based on fuzzy logic control for achieving high performance from induction motors. *Journal of Power Electronics*. 2013; 13(3):369-80. <https://doi.org/10.6113/JPE.2013.13.3.369>
- Rashag HF, Tan NML, Koh SP, Abdalla AN, Chong KH, Tiong SK. DTC-SVM based on PI torque and PI flux controllers to achieve high performance of induction motor. *Research Journal of Applied Sciences, Engineering and*

- Technology. 2014; 7(4):875-91. <https://doi.org/10.19026/rjaset.7.330>
3. Sreekala P, Sivasubramanian A. Speed control of brushless Dc motor with PI and fuzzy logic controller using resonant pole inverter. *IEEE PES Innovative Smart Grid Technologies*. 2011. PMID:21246270
  4. Yiasin S. An Analysis and Improvement of Brushless Dc Motor Control System. North Dakota State University; 2013.
  5. Rahman Z, Ehsani M, Butler KL. An investigation of electric motor drive characteristics for EV and HEV propulsion systems. *Future Transportation Technology Conference, SAE, Society of Automotive Engineers*. 2000. <https://doi.org/10.4271/2000-01-3062>
  6. Alexandridis AT, Galanos GD. Design of an optimal current regulator for weak AC/DC systems using Kalman filtering in the presence of unknown inputs. *IEEE Proceedings C Generation, Transmission and Distribution*. 1989; 136(2):57-63. <https://doi.org/10.1049/ip-c.1989.0010>
  7. Saif M. Robust servo design with applications. *IEE Proceedings D Control Theory and Applications*. 1993; 140(2):87-92. <https://doi.org/10.1049/ip-d.1993.0012>
  8. Marsh JF, Aldeen M. Decentralised observer-based control scheme for interconnected dynamical systems with unknown inputs. *IEE Proceedings – Control Theory and Applications*. 1999; 146(5):349-58. <https://doi.org/10.1049/ip-cta:19990540>
  9. Jaber A, Ahmad AZ, Abdalla A. Advance two-area load frequency control using particle swarm optimization scaled fuzzy logic. *Advanced Materials Research*. 2013; 622–623:80-5.
  10. Mohammed O. A Study of Control Systems for Brushless DC Motors. The University of Toledo Digital Repository. 2014.
  11. Iizuka K, Uzuhashi H, Kano M, Endo T, Mohri K. Microcomputer control for sensorless brushless motor. *IEEE Transactions on Industry Applications*. 1985; IA-21(3):595-601. <https://doi.org/10.1109/TIA.1985.349715>
  12. Raja Aris RSNA, Abdul Ghani ASAG, Muhd Zain ML. Enhancement of variable speed brushless DC motor using neural network. *Indian Journal of Science and Technology*. 2016; 9(14):1-9. <https://doi.org/10.17485/ijst/2016/v9i14/88728>
  13. Neethu K, Boopathi M, Giriraj Mannayee TCK. Fuzzy logic based speed control of BLDC motor on sensorless technique for space applications. *Indian Journal of Science and Technology*. 2016; 9(27):1-9. <https://doi.org/10.17485/ijst/2016/v9i27/78264>
  14. Moreira JG. Indirect sensing for rotor flux position of permanent magnet ac motors operating in a wide speed range. *IEEE Transactions on Industry Applications*. 1996; 32(6):1394-401. <https://doi.org/10.1109/28.556643>
  15. Becerra RC, Jahns TM, Ehsani M. Four-quadrant sensorless brushless ECM drive. *Conference Proceedings of 6th Annual Applied Power Electronics Conference and Exposition (APEC'91)*; 1991. p. 202–9.
  16. Herlambang S, Jones KO. Power system design using firefly algorithm for dynamic stability enhancement. *Indonesian Journal of Electrical Engineering and Computer Science*. 2016; 1(3):446-55. <https://doi.org/10.11591/ijeecs.v1.i3.pp446-455>
  17. Xin-She Y. *Firefly Algorithms for Multimodal Optimization*. Department of Engineering, University of Cambridge; 2009. p. 169-78