

# Novel BNC Placement Strategy for Wireless Body Area Networks

T. Pradeep, P. Vetrivelan \* and R. Latha

School of Electronics Engineering, VIT University, Chennai - 600127, Tamil Nadu, India; pradeep.t2014@vit.ac.in, vetrivelan.p@vit.ac.in, latha.r2015@vit.ac.in

## Abstract

**Objective:** Real-time monitoring of patients is considered as the key issues in managing healthcare system. Wireless Body Area Networks (WBAN) is one of the wise healthcare monitoring systems holding applications in numerous fields like medical, wellness, military, sports and so forth. The correspondence standard for Wireless Body Area Networks is characterized by the IEEE 802.15.6 for the operation around the human body. In WBAN, network longevity is one noteworthy issue confronted following the constrained energy supply in body nodes. **Methods:** The primary goal of this work is to expand the network lifetime, so a Modified Position Aware Algorithm is actualized where the spatial coordinates and battery status of every node is shared to all the nodes inside the network by incorporating the Probabilistic Energy Aware Routing (PER) and Body Node Coordinator (BNC) is versatile in the network. **Results:** A simulation result demonstrates that the network lifetime is reliably improved. The placement of BNC using the Modified Position-Aware BNC Placement algorithm along with the PER protocol improves the network lifetime reliably. **Application:** The proposed system facilitates to intimate the patient's critical parameters to the remote doctor in prior, this saves the diagnosis time and thus helps to save the Life.

**Keywords:** Patient, Body Area Networks (BAN), Body Node Coordinator (BNC), Network Longevity, Spatial Co-Ordinates

## 1. Introduction

Wireless technology has been dependably upgrading with time in discovering its path all along our parts of daily lives. Medicinal applications are a field where these kinds of technologies have a promising future. In the healthcare management field, get to and cost sparing are the most noteworthy issues nowadays. Wireless network technologies have something to contribute by helping with both of these issues.

WBAN's are progressively getting to be conceivable answers for health monitoring via on-body and differing medicinal. Existing health monitoring devices satisfy the point of being adept for long-term use. Nonetheless, there is a reaching accord that supplanting wired devices with Wearable Wireless Sensor Nodes (WWSNs), intended to gauge the fundamental indications of the patient's body, is more alluring because of the inherent freedom of movement that the wearer gains. It is a special purpose sensor network that goes about as an interface between

different sensors in and around the human body and the entire system. They comprise of a few physiological sensors joined to the human body or embedded in the body that will record and process the physiological changes and estimations, sending these estimations to an outside processing unit, which could be then transmitted to other external servers. One such application deals with "for health monitoring of a man recovering from heart attack".

WBAN is formally characterized by the IEEE 802.15 which belongs to Task group 6, as a communication standard enhanced for low-power devices operated in and around the human body to serve an assortment of utilizations including restorative. A WBAN interfaces these free hubs by utilizing a local controller, known as a BNC as shown in Figure 1. A BNC is essentially in charge of gathering data from hubs and sending them to the restorative focus. Generally, a cellular telephone or an individual Personal Data Assistant

\*Author for correspondence

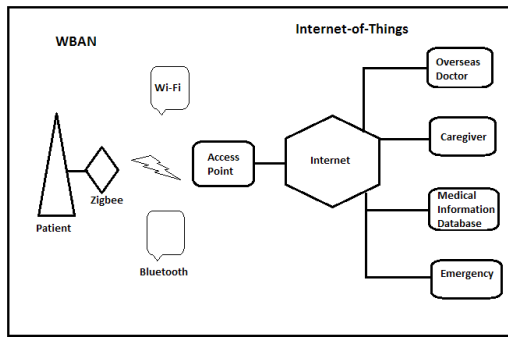

**Figure 1.** Overview of wireless BAN.

(PDA) is utilized as a BNC to organize the functionalities of body nodes.

The key challenge in WBAN is the effective energy consumption due to constrained energy supplies in the body sensor nodes. In the WBAN network, 80% of the energy is mainly utilized for the purpose of communication. Due to this, an efficient routing protocol plays a major role in communication which is having the direct impact on network lifetime. A routing protocol along with effective placement of node makes the entire system more energy efficient which is attracted by the researcher's widely.

This paper is composed in the following way. Section 2 depicts the related work, which explains the survey of works that has been carried out before. Novel Health-Care System working mechanism with the proposed algorithm and the used routing protocol is illustrated in the Section 3. System model and system parameters are detailed in the Section 4. Section 5 depicts the performance evaluation of the proposed system with the results and analysis. At last, Section 6 is the conclusion of this work.

In a WBAN, network life span is noteworthy due limited supply of energy to the body nodes. Consequently, a routing protocol plays a major role which makes the entire network energy efficient routing protocol together with an effective BNC deployment strategy will increase the network lifetime prominently<sup>1</sup>. WBAN which is based on ZigBee usually undergoes severe interference problems in the vicinity of Wireless networks. This issue is brought about by the way that most ZigBee channels cover with Wi-Fi channels, severely affecting the ability of healthcare monitoring systems to guarantee reliable delivery of physiological signals<sup>2</sup>. Coexistence causes severe interference problem which prominently affect the overall performance of WBANs. The present IEEE 802.15.4 standard needs components which viably deal with the conjunction

of mobile WBANs<sup>3</sup>. Energy efficiency is a standout amongst the most vital issues to be tended too. In a view of the Quality of Service (QoS) which is required from all the sensor nodes, intelligent time and energy resource is allocated to be performed for energy sparing. Because of the unique prerequisites of typical WBAN applications, network lifetime is characterized which tends to be maximized<sup>4</sup>. WBAN has seen many research trends which are depicted<sup>5</sup>. M2M is the affordable technology nowadays which is specified in standard BAN technology<sup>6</sup>. One of the energy aware routing protocols for WBAN is depicted in<sup>7</sup>. The improvement of WBAN is proved coexistence in<sup>8</sup>. The scheduling scheme for balancing lifetime and fairness is shown in<sup>9</sup>. A distributed scheme is fully implemented in<sup>10</sup>. WBAN provides the communication services among the body nodes, coordinator and personal health server. Most of the time energy of the nodes gets depleted very fast due to neighbor discovery. This discovery leads to increase in the latency as well shortening the entire lifetime<sup>11</sup>.

WBAN is mostly comprised of diverse bio-sensors to monitor human vitals, where those the sensors equipped with battery for power source and deployed it for a long use. WBAN MAC protocols are designed in such a way that it considers traffic class or load. So Multi-Dimensional Traffic Adaptive Energy-Efficient (MDTA) MAC provides complete solution for the multidimensional traffic to increase the network performance<sup>12</sup>. A new routing protocol has been proposed in order the make the network as energy efficient. The routing protocol is a cluster based routing protocol which clubs and combines the features of both the methods of direct and multi hop transmission. It considers the spatial coordinates and energy level of the nodes. The entire operation is centralized which reduces the computational load for the body nodes<sup>13</sup>. For allocating power, the power allocating strategies<sup>14</sup> are analyzed. Energy efficient transmission approach is based on threshold distance<sup>15</sup>. Minimizing the usage of power by the implant devices is core concept to enhance the network lifetime. The complexity and power consumption are transferred to the body nodes from the implant device, taking the account of replacing body nodes are much easier than implant devices<sup>16</sup>. The main motive of the work is to reduce the consumption on energy due to temporary changes and variations in the channel, transmission power etc. so an algorithm is proposed which alter the transmission power adaptively by feeding the feedback from the base station. Simulation results show

that the energy savings is lot more enhanced<sup>17</sup>. Adaptive cognitive enhanced platform<sup>18</sup> gives a clear vision of how adaptively WBAN performs. Each wireless body node has its own battery. So it is very much essential to maintain the battery for a long time increasing the network lifetime eminently. WBAN based recent technologies<sup>19-21</sup> are analyzed for improvement in healthcare techniques. These are issues arrived from the survey Network longevity is affected due to the limited supply of energy in body nodes.

The position of a BNC prominently impacts the life span of the whole WBAN. BNC is placed in such a way that the body nodes can easily access the coordinator where the transmission power is reduced so that battery level is maintained.

Network longevity is one of the major problems in Wireless Body Area Networks.

Computational and message exchange complexity must be minimum as possible so that data processing is reduced in the body node which eminently conserves energy.

## 2. Novel BNC Placement Strategy

### 2.1 Modified Position-Aware BNC Placement Algorithm

The nodes should be placed effectively in WBANs must possess the following characteristics:

- Message exchange and computational complexity must be least as possible.
- The whole operation must be centralized one.
- Sensor nodes must involve less in- order to make the network energy efficient.

Most of the techniques usually require large amount of computational support at the BNC. Heavy computation implies that the large data processing is processed in BNC. This information is gotten by existing node of the network. This expands the radio communication between a BNC and nodes, which in turn depletes the energy of nodes. Therefore, network lifetime decreases due to more energy consumption and complexity in computation.

Modified Position-aware BNC coordinator placement algorithm is possible only when the routing protocols knows the spatial information of the nodes. Since spatial information of the nodes is taken for the considerations there is no need to determine the relative distance. Modified Position-

aware BNC Placement algorithm (MPBP) involves low complexions compared to other node placement algorithms. The only problem is that it holds linear computational complexity. And also it takes into the account of the spatial coordinate location instead of considering their respective relative transmission distance with respect to BNC. Following are the considerations made for the algorithm:

- All the nodes in a WBAN should be within the transmission range of the BNC. The BNC must have the details about the spatial information of all the neighbor nodes in the network.
- In MPBP, the BNC must be placed within the network. Step by step details regarding the algorithm are depicted below.
- BNC computes the relative communication distances of nodes in the network which mainly considers their spatial coordinates.
- Relative communication distances ( $d_r$ ) and Utility Factor ( $U$ ) of all the nodes in the WBAN is computed by considering their respective available energy ( $E$ ).
- BNC computes the maximum utility factor from the available UFs (1) which is calculated in the previous step.

$$u_i = \left( \begin{matrix} \text{BN}_i \in u_i^{\max} \\ U \end{matrix} \right) - \frac{u_i}{u_i^{\max}} \left( \begin{matrix} \text{BN}_i \in u_i^{\max} \\ U \end{matrix} \right) \quad (1)$$

- Body Node Coordinator determines the maximum value of the Utility factor "u" from the available ones and then it normalizes the Utility factor "u" of each node with respect to the maximum value, which obtains  $\chi$ . Therefore, every node has its own  $\chi$ .
- At last, each and every node in the WBAN and multiply their own  $\chi$  with their respective coordinates and divide the resultant value with the total number of nodes in the WBAN.

Step 1: BNC is initially placed inside the WBAN network.

Step 2: Relative distances of the body nodes is calculated ( $d_{r1}, d_{r2}, \dots, d_{rn}$ ) from BN

$$\text{for all BN: BN}_i \in V_i$$

Step 3: Utility factor for each node is calculated using Equation (2).

$$U(\text{BN})_i = \frac{\text{available energy of BN}_i}{([d_{r_i}]^n)} \quad (2)$$

Step 4: Maximum value of the utility factor is determined using Equation (3).

$$u_i = \frac{\max_{BN_i \in V_i} U - U(BN_i)}{\max_{BN_i \in V_i} U} \quad (3)$$

Step 5:  $X$ , which the normalize value of all the 'u' is given by Equation (4a) and (4b).

$$X_i = \frac{u_i}{\max_{BN_i \in V_i} u} \quad (4a)$$

Step 6: BNC is replaced to new position at the point  $(X_{new}, Y_{new})$ .

$$\equiv \frac{\sum_{i=1}^{BN_i}(x_i, X_i)}{\#V_i}, \frac{\sum_{i=1}^{BN_i}(x_i, Y_i)}{\#V_i} \quad (4b)$$

## 2.2 Probabilistic Energy Aware Routing Protocol (PER)

PER is mainly based on the probabilistic metric and it is a centralized routing protocol. The Probabilistic metric can be easily explained as the node's delivery predictability where it predicts the delivery of data packets to its destination. A decision is confirmed whether to forward the message or not by using the delivery predictability. PER is mainly expressed by the utility function which considers other parameters which is as follows:

- The power or energy which is available in the receiver node.
- Path loss determined for the receiver and transmission node.
- Traffic congestion is considered by how frequently the receiver node is made utilized by the neighbor nodes in order to reach BNC.

There are two types of nodes which plays a major role in this routing protocol. They are:

### 2.2.1 Neighbor Node

A node is said to be a neighbor node only if it satisfies the below condition. Considering BN1 is a neighbor node to BN2,

$$\{Dis(BN_2, BN_1) \leq Trs_{max}(BN_2)\} \& \{Dis(BN_2, BNC) > Dis(BN_2, BNC)\} \& \{Dis(BN_2, BN_1) < Dis(BN_2, BNC)\}$$

### 2.2.2 Relay Node

A node is said to be a relay node only if it satisfies the below equation. Considering N1 is the relay node to N2,

$$\{Dis(BN_1, BN_2) \leq Trs_{max}(BN_2)\} \& \{Dis(BN_2, BNC) > Dis(BN_1, BNC)\} \& \{Dis(BN_1, BN_2) < Dis(BN_2, BNC)\}$$

Where Dis  $(BN_1, BN_2)$  is the relative communication distance in between the nodes  $BN_1$  and  $BN_2$ ,  $Trs_{max}(BN_1)$  is maximum transmission coverage distance of the node  $BN_1$ . BN represents the Body Node and Trs represents the transmission distance. Entire routing protocol is based on the Delivery Predictability estimation. The decision are totally depend on it whether to forward the message or not to the other nodes. The delivery predictability is computed using the Equation (5).

$$P_{i,j} = \alpha \cdot U_{pi} + \beta \cdot U_{AEi} + U_{Ti} \quad (5)$$

### 2.2.3 Traffic Congestion Utility Factor - $U_T$

This utility factor is calculated by using the Equation (8),

$$\text{for all BN at any instant } t, \\ T_i(t) = \delta T_i(t) + (\delta - 1)T_i(t - Tw) \quad (6)$$

$$T_i(t) = \delta T_i(t) + (\delta - 1)T_i(t - Tw)$$

$$T_i = \frac{\text{Sleeping time during } T_w}{\text{Fixed time frame or window, } T_w}$$

$$UT_i = \frac{T_i}{\epsilon_T + \max_{BN_i \in V_i} T_i} \quad (7)$$

$$UT_i = \frac{T_i}{\max_{BN_i \in V_i} T_i} \quad (8)$$

Where  $\delta$  is the damping factor.

### 2.2.4 Available Energy Utility Factor - $U_{AE}$

The available energy utility factor is calculated through the Equation (12),

$$\text{for all } BN_i: U_{AEi} = E_{ai} + E_{avi} \quad (9)$$

$$E_{avi} = \frac{E_{avail i}}{\epsilon_E + \max_{BN_i \in V_i} E_{avail i}} \quad (10)$$

$$E_{ai} = \frac{\text{Available energy level of node } i (E_{avail i})}{\text{Initial energy level of node } i} \quad (11)$$

$$U_{AEi} = \frac{U_{AEi}}{\max_{N_i \in U_{AEi}}} \quad (12)$$

Where  $E_{av_i}$  is the available energy in the receiver node  $i$ ,  $E_{a_i}$  is the available energy with respect to the initial value.



### 2.2.5 Path Loss Utility Factor - $U_p$

$$\text{for all } BN_i, U_{P_i} = 1 - \frac{P_{BN_i, BN_i}}{\max_i BN_i \in P_{BN_i} BN_i} \quad (13)$$

$$U_{P_i} = \frac{U_{P_i}}{\max_i BN_i \in V_i U_{P_i}} \quad (14)$$

The Path Loss Utility Factor is calculated using the Equation (14), Where  $P_{BN_i, BN_j}$  is the path loss between these two nodes.  $\alpha$  is the measurement of discrepancy which depends on the  $U_p$  and  $U_T$ ,  $\beta$  is the measurement of discrepancy which depends on  $U_{AE}$  and  $U_T$ .

## 3. Novel BNC Placement Strategy Implementation

The scenario of this network is built using the OMNeT++ with MiXiM framework. The existing and proposed system is evaluated for the simulation time of 150 seconds in order to analyze the performance metrics of PBP algorithm with PER protocol.

### 3.1 Software Resource

The software resource utilized here is OMNeT++ 4.4.1 simulator. OMNeT++ is an extensible, particular, segment based C++ simulation library, essentially to build network simulation. It is implied in a more extensive sense that incorporates wired and wireless communication networks. It provides a component architecture which are programmed in C++, then assembled as a whole model using a high level language (NED). TKENV is the graphical runtime environment which is more helpful to inspect each component, debugging, tracing etc. The executing module and the environment functions are synced by SIM along with linked model components.

### 3.2 Simulation Parameters

Simulation is done using OMNeT++. The body nodes along with the coordinator are stretched in a playground field by 250 x 250 x 250 m as shown in the Figure 3. There are two scenarios created and evaluated. Table 1 shows the simulation parameters as well as their values.

### 3.3 Path Loss Model

In order to determine the path loss between two nodes, long-distance path loss model (2) is utilized here.

**Table 1.** Simulation parameters

Simulation parameters	Values
Terrain	250 x 250 x 250 m
Nodes	9
Simulation time	150 s
Battery capacity	1000 mAh
Battery Voltage	3.3 V
Routing protocol	PER

$$PL_{dB} = PL_{0,dB} + 10 * \eta * \frac{\log d}{d_n} \quad (15)$$

In the equation (15),  $PL_{0,dB}$  is the reference path loss which is at the path loss exponent  $\eta$  and reference distance  $d_0$ .

Figure 2 shows the existing scenario where the WBAN network is formed using PER routing protocol. The existing work does not contain the BNC node placement algorithm but it contains only the PER routing protocol for body area networks. WBAN is created using 9 body nodes and a single coordinator. Link is made between the body nodes and the coordinator, where it connects to the network. Each node displays its battery level and energy consumption is higher decreasing the network lifetime. In order to increase the energy efficiency following Position Aware BNC placement algorithm is implemented.

Figure 3 contains the proposed work where there are nine body nodes, a BNC, Base network and world network. The whole network assumes that each node has its own battery and communicated to the BNC. This second scenario is implemented by BNC algorithm using the Probabilistic energy-aware routing protocol. In Figure 4 the human body acts as the node and it sends the sensed data to the BS which acts as the BNC and also the BNC is further connected to PDA or any mobile system. In our system, sink acts as the mobile device which receives the data from BNC where it gets the sensed data from the human nodes. Initially the BNC is placed in a position and the position is changed by computing the MPBP algorithm. The entire data is communicated to BaseWorldUtility which acts as the home network and sensed data can be retrieved anywhere within the network.

The network of human nodes is created which is wireless and the sensed data are sent to BS and the BS transmits the data to a mobile node hence the data received with higher effective time and node placement also calculated accordingly. The energy level of the node is also maintained and the graph is plotted accordingly.

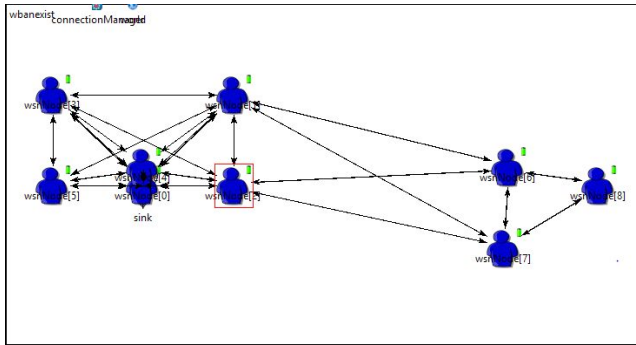

Figure 2. PER based WBAN.

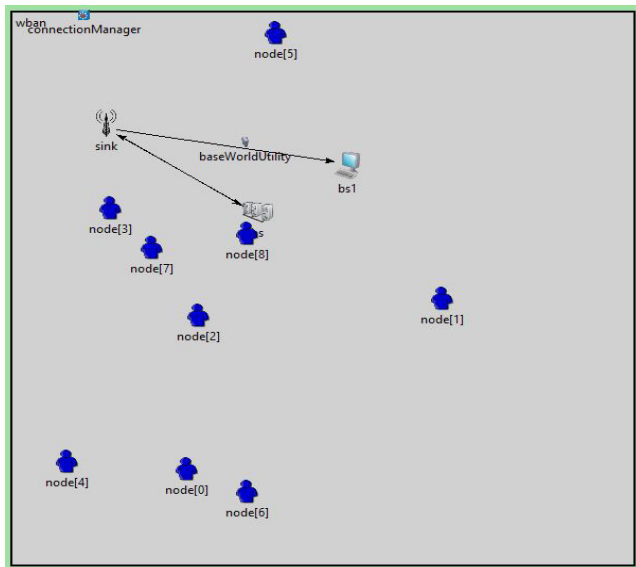

Figure 3. PBP with PER based WBAN.

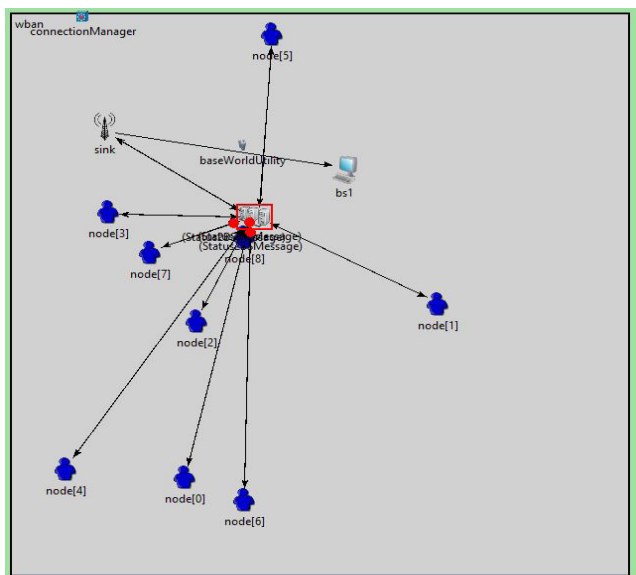

Figure 4. Proposed scenario-sensed data communicated.

The E-log file is generated and recorded throughout the simulation. Each E-log window figure represents the algorithm implementation in different view. The E-log file records each and every parameter detail during the simulation. Figure 5 shows that the nodes are initialized and connection is made by exchanging the message. It gives the clear picture about the message sent from a node to establish connection. Figure 6 depicts the information that each node possess. Each node has the spatial information and energy of the other neighbor nodes too. Each node holds the information regarding the spatial coordinates for calculating relative distance which reduces complexity in computation.

### 4. Performance Evaluation

Performance of the system is evaluated using the following performance metrics:

```

Details
  -> Creating connection from module (PhyLayer80211p) wbanexist.sink.nic.phy80211p gate out15-1 to module (cCompoundModule) wbanexist.sink.nic gate out15-1
  -> Creating gate in21-1 in module (cCompoundModule) wbanexist.wsnNode[0]
  -> Creating gate in21-1 in module (cCompoundModule) wbanexist.wsnNode[0].nic
  -> Creating connection from module (cCompoundModule) wbanexist.wsnNode[0] gate in21-1 to module (cCompoundModule) wbanexist.wsnNode[0].nic gate in21
  -> Creating gate in21-1 in module (PhyLayerBattery) wbanexist.wsnNode[0].nic.phy
  -> Creating connection from module (cCompoundModule) wbanexist.wsnNode[0].nic gate in21-1 to module (PhyLayerBattery) wbanexist.wsnNode[0].nic.phy gate i
  -> Creating connection from module (cCompoundModule) wbanexist.sink gate out15-1 to module (cCompoundModule) wbanexist.wsnNode[0] gate in21-1
  -> Display string changed for module (cCompoundModule) wbanexist.wsnNode[0] to is=vlps=300.00000,328(z=status/battery/bgb=210,450:white=abstract/person=b=0)
  -> Display string changed for module (cCompoundModule) wbanexist.wsnNode[0] to is=vlps=300.00000,400.00000(z=status/battery/bgb=210,450:white=abstract/person
  End calling module
  [P] Begin calling initialize() in module (BMacLayer) wbanexist.wsnNode[0].nic.mac
  -> Creating message (cMessage) wakeup
  -> Creating message (cMessage) data_timeout
  -> Creating message (cMessage) data_tx_over
  -> Creating message (cMessage) stop_preamble
  -> Creating message (cMessage) send_preamble
  -> Creating message (cMessage) ack_tx_over
  -> Creating message (cMessage) cca_timeout
  -> Creating message (cMessage) send_act
  -> Creating message (cMessage) start_bmac
  -> Creating message (cMessage) ack_timeout
  -> Creating message (cMessage) resend_data
  -> Scheduling self message (cMessage) start_bmac for 0s, now + 0s kind = 196
  -> Arrival at 0s, now + 0s
  End calling module
  [P] Begin calling initialize() in module (PhyLayerBattery) wbanexist.wsnNode[0].nic.phy
  -> Begin calling method in module (SimpleBattery) wbanexist.wsnNode[0].battery from module (PhyLayerBattery) wbanexist.wsnNode[0].nic.phy
  End calling module
    
```

Figure 5. E-log window-node connection initialization.

```

Details
  X Deleting message (cMessage) init
  Event in module (Node) wban.node[3] on arrival of self message (cMessage) init called from module (cCompoundModule) wban
  numNodes is: 9 energy: 499912 module-id:20
  -> Creating connection from module (Node) node[3] gate out[0] to module (BS) wban.bs gate in[4]
  -> Creating connection from module (BS) wban.bs gate out[4] to module (Node) node[3] gate in[0]
  id:2 =1466 y:543
  id:3 =1962 y:84
  id:4 =373 y:1877
  id:5 =1630 y:256
  id:6 =174 y:1624
  id:7 =945 y:72
  id:8 =755 y:1733
  id:9 =448 y:850
  id:10 =755 y:797
  -> Creating message (cMessage)
  in send2855
  -> Sending message (Status285Message) arriving at 0s, now + 0s kind = 0 length = 0
  -> Sending through module (Node) node[3] gate out[0]
  -> Arrival at 0s, now + 0s
  X Deleting message (cMessage) init
  Event in module (Node) wban.node[4] on arrival of self message (cMessage) init called from module (cCompoundModule) wban
  numNodes is: 9 energy: 499907 module-id:20
  -> Creating connection from module (Node) node[4] gate out[0] to module (BS) wban.bs gate in[5]
  -> Creating connection from module (BS) wban.bs gate out[5] to module (Node) node[4] gate in[0]
  id:2 =1466 y:543
  id:3 =1962 y:84
  id:4 =373 y:1877
  id:5 =1578 y:973
  id:6 =23 y:1723
    
```

Figure 6. E-log window-spatial information of node

### 4.1 Performance Metrics

- **Energy Consumption:** Energy consumption is the measure of energy devoured by the entire network in the simulated time.
- **Throughput:** Throughput depicts the number of packets effectively delivered to their end destination per unit time.
- **Packet Drop:** Packet drop is the measure of the percentage of packets lost during the simulation time.
- **Packet Delivery Ratio (PDR):** Packet Delivery Ratio gives insights about the proportion of the total data packets efficiently delivered to data packets created by the source.

### 4.2 Throughput

It can be observed from the Figure 7 that the proposed scheme has more throughput compared to the existing scenario. Moreover, throughput increases when the simulation time increases because exchange of packet is minimum at starting of the simulation.

### 4.3 Energy Consumption

Energy consumption of the entire WBAN network is shown in Figure 8. There are slight variations between the existing and proposed, but overall energy consumption is economy when compared to the existing work.

### 4.4 Packet Delivery Ratio (PDR)

The PDR is given in Figure 9. From the Figure 10 it is clearly identified that the Packet Delivery Ratio is constant and high throughout the network simulation time compared to the existing work.

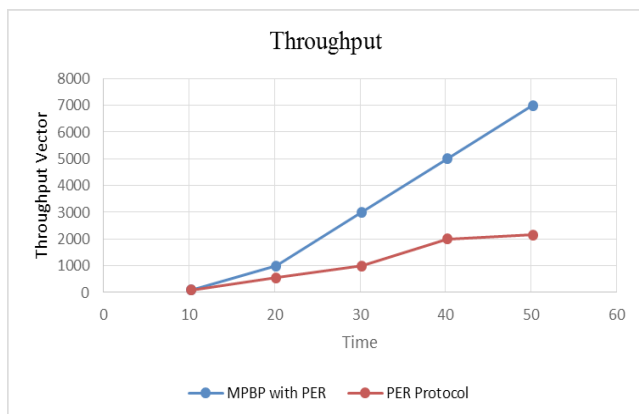

Figure 7. Throughput comparison.

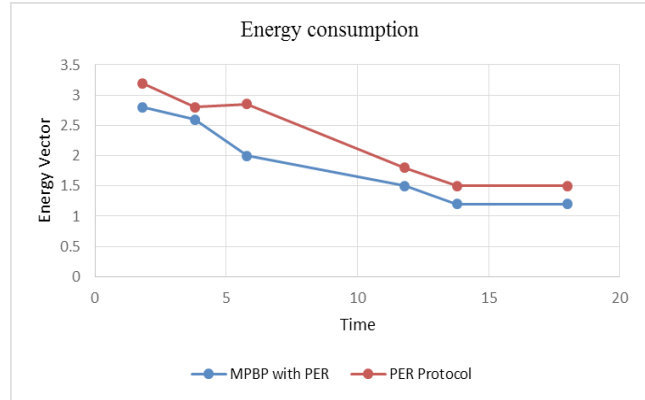

Figure 8. Energy consumption comparison.

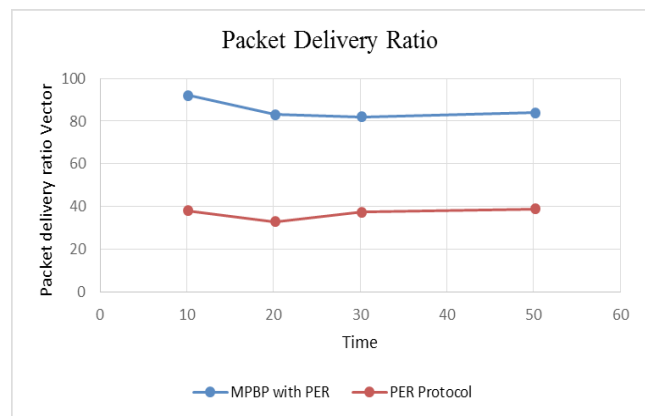

Figure 9. Packet Delivery Ratio comparison.

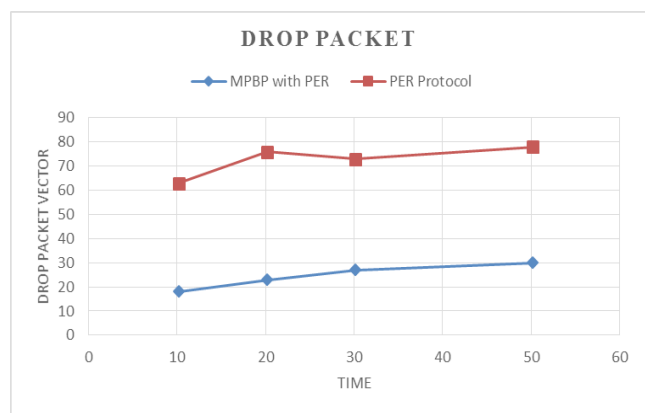

Figure 10. Packet Drop comparison.

### 4.5 Packet Drop

Figure 10 shows the packet loss comparison. Packet loss or drop is very minimum throughout the lifetime because of the PER protocol. Comparatively the proposed scheme has more economy.

## 5. Conclusion

The importance of the BNC placement is depicted in the above work which is very much essential to prolong the network lifetime along with the Probabilistic energy aware routing. The proposed algorithm enhances the network lifetime by reducing the computation complexity. The simulation results shows that the energy consumption is less and throughput also shows the huge difference in the comparison graph. In future the performance of the implemented algorithm is assessed as far as reliability and control message overheads.

## 6. Acknowledgement

Authors would like to thank the anonymous reviewers for their comments in improving the paper and also we extend our gratitude to VIT University, Chennai for their support.

## 8. References

1. ul Huque MTI, Munasinghe KS, Jamalipour A. Body node coordinator placement algorithm for Wireless Body Area Networks. *IEEE Internet of Things Journal*. 2015; 6(8):11–6.
2. Kim Y, Lee S. Coexistence of ZigBee-based WBAN and Wi-Fi for health tele-monitoring systems. *IEEE Journals and Magazines*. 2015; 6(4):113–9.
3. Deylami MN, Jovanov E. A distributed scheme to manage the dynamic coexistence of IEEE 802.15.4-based health monitoring WBANs. *IEEE Journals and Magazines*. 2014; 15(17):12–9.
4. Zhou X, Zhang T, Song L, Zhang Q. Energy efficiency optimization by resource allocation in Wireless Body Area Networks. *IEEE Conference Publications*. 2014; 6(9):78–83.
5. Maman M, Denis B, D'Errico R. Research trends in Wireless Body Area Networks. *IEEE Conference Publications*. 2014; 7(9):66–73.
6. Kurod M, Fukahori M. Affordable M2M enabled E-health using standard BAN Technology. *IEEE Conference Publications*. 2014; 7(11):56–61.
7. ul Huque MTI, Munasinghe KS, Jamalipour A. A probabilistic energy-aware routing protocol for Wireless Body Area Networks. *IEEE Conference Publications*. 2014; 8(10):56–62.
8. Sarra E, Mounгла H, Benayoune S, Mehaoua A. Coexistence improvement of Wearable Body Area Network (WBAN) in medical environment. *IEEE Conference Publications*. 2014; 15(14):112–20.
9. Yin Y, Hu F, Deng Y, Zhao L. New distributed transmission scheduling scheme for balancing lifetime and fairness in WBAN. *IEEE Conference Publications*. 2013; 6(8):11–6.
10. Deylami M, Jovanov E. An implementation of a distributed scheme for managing the dynamic coexistence of Wireless Body Area Networks. *IEEE Conference Publications*. 2013; 6(4):113–9.
11. Nam HS, Jung KI, Kim DY. An energy efficient discovery algorithm for opportunistic WBAN systems. *IEEE Conference Publications*. 2011; 7(11):56–61.
12. Hossain MU, Dilruba, Kalyan M, Rana MR, Rahman MO. Multi-dimensional traffic adaptive energy-efficient MAC protocol for Wireless Body Area Networks. *IEEE Conference Publications*. 2014; 6(9):78–83.
13. ul Huque MTI, Munasinghe KS, Abolhasan M, Jamalipour A. Energy efficient adaptive routing protocol for Wireless Body Area Networks. *IEEE Conference Publications*. 2013; 7(9):66–73.
14. Kailas A. Power allocating strategies to minimize energy consumption in Wireless Body Area Networks. *IEEE Conference Publications*. 2011; 9(7):1111–23.
15. Yi C, Wang L, Li Y. Energy efficient transmission approach for WBAN based on threshold distance. *IEEE Journals and Magazines*. 2015; 11(16):23–9.
16. Ntouni GD, Lioumpas AS, Nikita KS. Reliable and energy efficient communications for Wireless Biomedical Implant Systems. *IEEE Journals and Magazines*. 2014; 44(15):234–40.
17. Sodhro AH, Li Y, Shah MA. Energy-efficient adaptive transmission power control for Wireless Body Area Networks. *IEEE Journals and Magazines*. 2016; 56(4):44–52.
18. Shen Q, Liu J, Yu H, Ma Z, Li M, Shen Z, Chen C. Adaptive cognitive enhanced platform for WBAN. *IEEE Conference Publications*. 2013; 6(6):34–40.
19. Ramakrishnan M. Switch pattern encryption based WBAN security in an IoT. *Indian Journal of Science and Technology*. 2015 Dec; 8(34):56–64.
20. Amutha B, Manickavasagam B, Patnaik A, Nanmaran K. Erection of comprehensive wellness program for global healthcare monitoring system using AODV protocol with data clustering scheme. *Indian Journal of Science and Technology*. 2015 Aug; 8(17):5–11.
21. Rao J, Kameswara Rao M. An RTOS based architecture for patient monitoring system with sensors networks. 2016 May; 9(17):34–40.