

# Design and Analysis of ANFIS based BLDC Motor

M. Yashoda\* and O. Chandra Sekhar

EEE Department, K L University, Vaddeswaram - 522502, A.P, India; myashoda32@gmail.com, sekharobbu@kluniversity.in

## Abstract

**Objective:** This paper defines a new Adaptive Neuro Fuzzy Interface System (ANFIS) controller based Brush Less DC motor (BLDC). **Methods:** This operation can achieved by ANFIS based controller, ANFIS can reduce error for reference and measured value effectively and faster acting to dynamic speeds. **Findings:** Due to the increased industrialization the requirements of variable speed machines/drives going on increasing. Most of automated systems BLDC motors are used due to its faster response and highly stable. **Applications:** Due to these applications the ANFIS based BLDC motor performance is higher than conventional BLDC control.

**Keywords:** ANFIS, BLDC Control, BLDC Motor, Electric Drive, Speed Machines/Drives

## 1. Introduction

The increasing industrial automation requires fast and accurate control drives to perform required task. Generally different types of drives are available those are DC and AC drives. Among all this BLDC plays a key role in design of automated systems. Brushed DC motor has some advantages than induction motors, they have good torque speed characteristics and they have high efficiency<sup>1</sup>. BLDC was special design in brushed DC motor, in this brushes are eliminated by placing permanent magnets on rotor. BLDC have improved efficiency, less loss; spark less due to absent of brushes, fast response and noise free. Due to those advantages BLDC plays a key role in design of servo mechanism used in automation<sup>2-4</sup>. The control of BLDC is designed to get fast response during speed variations corresponding to speed variation required. The controller make the BLDC dynamically stable and less study state error, i.e.; BLDC speed is closer to its reference.

The different types of controllers are available for mitigating error; those are PID controller, hysteresis controller, PR controller, Fuzzy logic controller and ANFIS. In these PID, Hysteresis, and PR are conventional techniques<sup>5,6</sup>. The Fuzzy and ANFIS are the soft computing techniques used for BLDC control. The proposed system consists ANFIS based controller for speed controlling. ANFIS is a rule based trained system, it is faster

acting, less steady state error and highly stable. It can improve system response greater than fuzzy logic controller<sup>7</sup>. Figure 1 shows proposed test system here sensor less speed controlling technique is used. The measured speed is fetched from current drawn by motor and it was compared with reference. The error between measured and reference is reduced by ANFIS controller closer to reference.

## 2. Design of BLDC

The BLDC motor is design based on its current reference and voltage equations. The proposed system controlled with ANFIS controller<sup>8</sup>. The controlling action divided in to two parts. The ANFIS controller was included in outer speed control loop; other is inner current control loop. Outer control loop for speed control and inner for torque control of machine. The simulink design of ANFIS based BLDC as shown in Figure 5.

The BLDC motor design was performed based on some considerations, those considerations are inductances are constant, motor core does not saturates; the resistances of all phases are same. The constant losses are equal to zero, the magnitudes of EMFs induced in three phases are equal and the losses in power electronic devices are equal to zero.

\*Author for correspondence

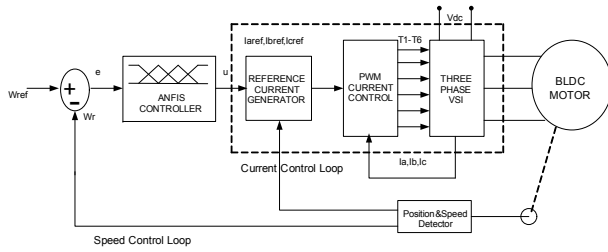

Figure 1. ANFIS controlled BLDC motor system.

$$\begin{bmatrix} V_a \\ V_b \\ V_c \end{bmatrix} = \begin{bmatrix} R & 0 & 0 \\ 0 & R & 0 \\ 0 & 0 & R \end{bmatrix} \begin{bmatrix} i_a \\ i_b \\ i_c \end{bmatrix} + \begin{bmatrix} (L - M) & 0 & 0 \\ 0 & (L - M) & 0 \\ 0 & 0 & (L - M) \end{bmatrix} \frac{d}{dt} \begin{bmatrix} i_a \\ i_b \\ i_c \end{bmatrix} + \begin{bmatrix} e_a \\ e_b \\ e_c \end{bmatrix}$$

Here,  $V_a, V_b,$  and  $V_c$  are phase voltages,  $R$  is resistance,  $L$  is inductance,  $M$  is mutual inductance,  $e_a, e_b$  and  $e_c$  are trapezoidal back EMFs.

$$\frac{d\omega_m}{dt} = \left(\frac{P}{2J}\right) (T_e - T_L - B\omega_r) \text{ and } \frac{d\theta}{dt} = \omega_r$$

Here,  $T_e$  and  $T_L$  are the electromagnetic and load torques of BLDC motor.

### 3. Modelling of Trapezoidal EMF

The rotor position plays a key role on EMF generation<sup>2</sup>. The rotor position depends on speed of machine, than the EMF generated in machine is depends on speed of machine<sup>10</sup>.

$$\begin{bmatrix} e_a \\ e_b \\ e_c \end{bmatrix} = E \begin{bmatrix} f_a(\theta) \\ f_b(\theta) \\ f_c(\theta) \end{bmatrix}, (E = k_e \omega_r)$$

Where  $e_a$  is EMF generated and  $f_a(\theta)$  function of rotor position.

$$f_a(\theta) = \begin{cases} \left(\frac{6}{\pi}\right) \left(0 < \theta \leq \frac{\pi}{6}\right) \\ 1 & \left(\frac{\pi}{6} < \theta \leq \frac{5\pi}{6}\right) \\ -\left(\frac{6}{\pi}\right) \theta + 6 & \left(\frac{5\pi}{6} < \theta \leq \frac{7\pi}{6}\right) \\ -1 & \left(\frac{7\pi}{6} < \theta \leq \frac{11\pi}{6}\right) \\ \left(\frac{6}{\pi}\right) \theta - 12 & \left(\frac{11\pi}{6} < \theta \leq 2\pi\right) \end{cases}$$

$f_b(\theta)$  and  $f_c(\theta)$  calculation same as  $f_a(\theta)$ , the torque is

$$T_e = (T_a + T_b + T_c) = \frac{e_a i_a + e_b i_b + e_c i_c}{\omega_r}$$

From equation (3)-(4)

$$T_e = k_e (f_a(\theta) i_a + f_b(\theta) i_b + f_c(\theta) i_c)$$

The trapezoidal EMF generated was defined<sup>11,12</sup>. The relation between speed and torque is defined as

$$\omega_m = \frac{P}{2J} \int (T_e - T_L) dt = \frac{P}{2J} \int [(T_a + T_b + T_c) - T_L] dt$$

### 4. Voltage Source Inverter (VSI)

From the Figure 2 the phase to phase voltages are taken to fetch currents<sup>13,14</sup>.

$$\begin{aligned} V_{ab} &= 2Ri_1 + 2(L - M) \frac{di_1}{dt} + e_{ab} \\ V_{bc} &= 2Ri_2 + 2(L - M) \frac{di_2}{dt} + e_{bc} \\ V_{ca} &= 2Ri_3 + 2(L - M) \frac{di_3}{dt} + e_{ca} \end{aligned}$$

DC supply voltage at mid points is

$$\begin{aligned} V_{ao} &= \frac{V_d}{2} S_{-a} = \frac{V_d}{2} \sum_0^{\infty} A_n \sin(n\omega t) \\ V_{bo} &= \frac{V_d}{2} S_{-b} = \frac{V_d}{2} \sum_0^{\infty} A_n \sin[n(\omega t - 120)] \\ V_{co} &= \frac{V_d}{2} S_{-c} = \frac{V_d}{2} \sum_0^{\infty} A_n \sin[n(\omega t - 240)] \end{aligned}$$

### 5. Reference Current Generator

The current references are generated from rotor position and reference phase currents, by considering current at maximum condition ( $I_{max}$ ).

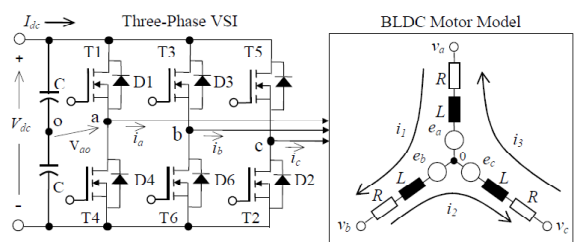

Figure 2. Inverter and Motor equivalent circuit

$$I_{max} = u / t$$

Where ( $u$ ) is modified error from ANFIS and  $t$  is torque constant.

### 6. Current Control Block

The motor currents and reference currents for PWM generator are calculated. The hysteresis controlled pulse generation is included. The switching pulses are generated based on motor currents, rotor position and  $I_{max}$ <sup>15</sup>. The pulse generated is done from below equations.

$$e_{ia} = i_{aref} - i_a$$

$$e_{ib} = i_{bref}$$

$$e_{ic} = i_{cref} - i_c$$

$$if e_{ia} \geq h_b then V_{ao} = \frac{V_{dc}}{2},$$

$$if e_{ia} \leq h_b then V_{ao} = \frac{-V_{dc}}{2}$$

$$if e_{ib} \geq h_b then V_{bo} = \frac{V_{dc}}{2},$$

$$if e_{ib} \leq h_b then V_{bo} = \frac{-V_{dc}}{2}$$

$$if e_{ic} \geq h_b then V_{co} = \frac{V_{dc}}{2},$$

$$if e_{ic} \leq h_b then V_{co} = \frac{-V_{dc}}{2}$$

The BLDC Reference currents are represented in the Table 1.

### 7. Design of Adaptive Neuro-Fuzzy Mechanism (ANFIS)

Adaptive neuro-fuzzy technique (or Adaptive Neuro-Fuzzy Inference Controlling System, ANFIS) has been suitably

Table 1. BLDC Reference currents

| Rotor position | Reference currents |             |             |
|----------------|--------------------|-------------|-------------|
|                | $i_{aref}$         | $i_{bref}$  | $i_{cref}$  |
| 0–30           | 0                  | - $I_{max}$ | $I_{max}$   |
| 30–90          | $I_{max}$          | - $I_{max}$ | 0           |
| 90–150         | $I_{max}$          | 0           | - $I_{max}$ |
| 150–210        | 0                  | $I_{max}$   | - $I_{max}$ |
| 210–270        | - $I_{max}$        | $I_{max}$   | 0           |
| 270–330        | - $I_{max}$        | 0           | $I_{max}$   |
| 330–260        | 0                  | - $I_{max}$ | $I_{max}$   |

involved in the designing of Fuzzy Inference System (FIS). The architecture of ANFIS is shown in Figure 3. In this context, the designing has been accomplished with sugeno type technique that lines out the input characteristics to input membership functions. Fuzzy inference is applicable to only modelling system whose structure is virtually designed by the user’s perception of the variable characteristics modelled in the inference system<sup>16</sup>. In some sort of designing conditions it may not be easy to analyze the data of the membership functions it should be more correlate with the membership function promptly. A network-type design same as neural network system has been adopted to strengthen and improve the input/output map such a way that it is ample to measure the input units through the pre mentioned membership functions of input/output parameters that are correlated with the membership functions which can be altered through the learning procedure<sup>17</sup>. In the process of calculation, the variable parameter changes are supplemented with a gradient vector, which has been used as reference to the FIS to measure the input/output data in correspondence with the pre-determined parameters. The simulink diagram of proposed ANFIS control is shown in Figure 4.

#### 7.1 Simulation Results

The design parameters of BLDC motor is mentioned in Table 2.

The EMF induced in three phases based on rotor position is shown in Figure 6.

The switching pulses generated for inverter control is as shown in Figure 7. The inverter current and line to line voltage output from inverter is as shown in Figure 8.

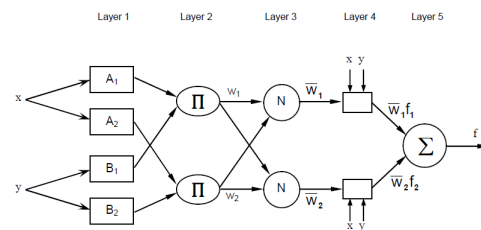

Figure 3. The architecture of the ANFIS.

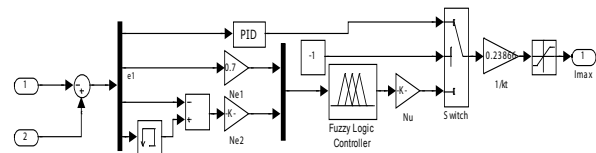
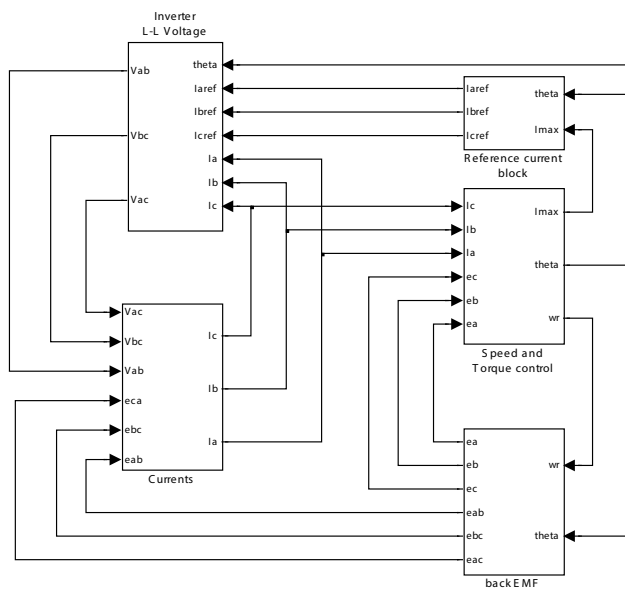

Figure 4. Proposed ANFIS control.

**Table 2.** Parameters of BLDC motor

| Type                                 | Parameter                 |
|--------------------------------------|---------------------------|
| BLDC motor type Ametek               | 119003-01                 |
| Rating ( $P$ )                       | 106warr                   |
| Number of Phase (Connection)         | 3(star)                   |
| Rated speed                          | 4228 rpm                  |
| Rated current                        | 6.8A                      |
| Stator equivalent resistance( $R$ )  | 0.348V                    |
| Stator equivalent inductance ( $L$ ) | 0.314 mH                  |
| Moment of inertia ( $J$ )            | 0.0019 Ncm-s <sup>2</sup> |
| Number of Pole ( $p$ )               | 8                         |
| Voltage constant ( $ke$ )            | 0.0419 V/rad/s            |
| Torque constant ( $kt$ )             | 4.19 Ncm/A                |



**Figure 5.** Simulink model of BLDC motor.

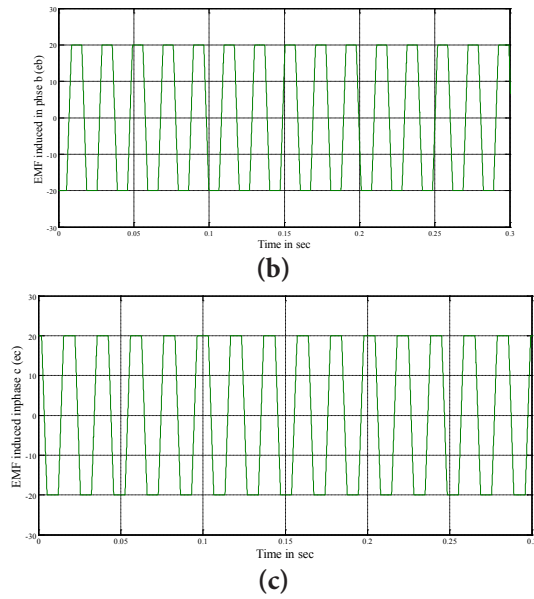
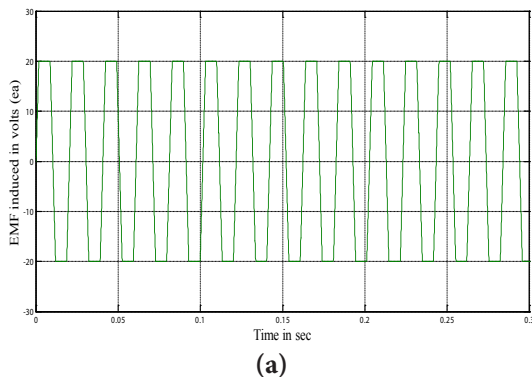

**Figure 6.** Figure 6. (a) Emf induced in BLDC motor in phase-A. (b) Emf induced in BLDC motor in phase-B. (c) Emf induced in BLDC motor in phase-C

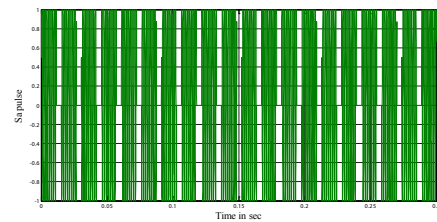

**Figure 7.** Switching function pulse generation  $S_{a\_a}$ .

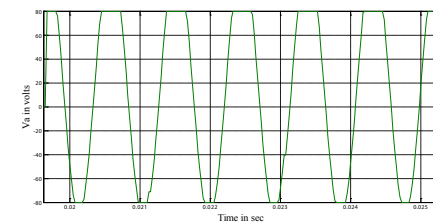
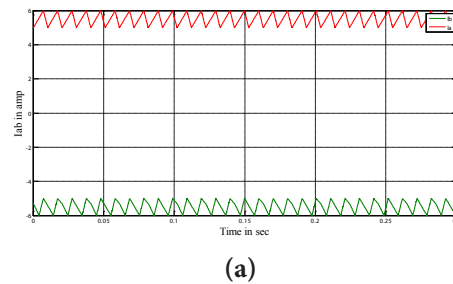

**Figure 8.** (a) Inverter Current outputs. (b) Line to Line Voltage.

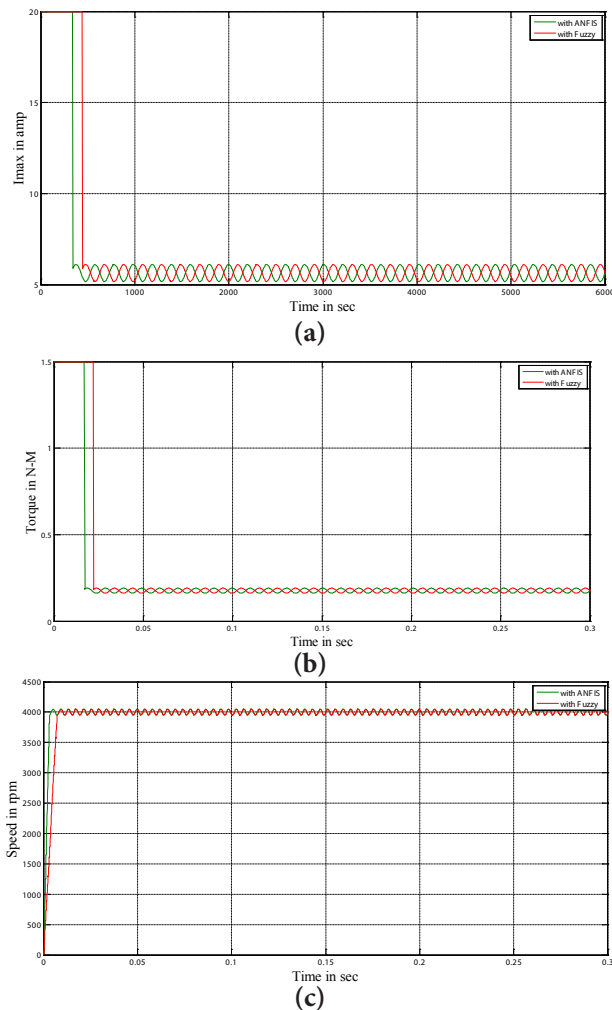

**Figure 9.** (a) Comparison between Fuzzy and ANFIS controlled BLDC,  $I_{max}$ . (b) Comparison between Fuzzy and ANFIS controlled BLDC, Torque. (c) Comparison between Fuzzy and ANFIS controlled BLDC, Speed of BLDC.

Figure 9(a), Figure 9(b) and Figure 9(c), show the motor current, Torque and speed of BLDC motor in conventional and proposed control mode operations. The deviation between Fuzzy based response to ANFIS based response justifies ANFIS controller is faster acting and highly stable one.

## 8. Conclusions

- This paper defines, the performance of ANFIS based BLDC drive is higher than conventional fuzzy controlled BLDC. It can be justified by doing comparative study among ANFIS and fuzzy based BLDC simulink design.

- The ANFIS based BLDC time taken to reach steady state value is less compared to Fuzzy based BLDC. Those are studied from speed torque responses.

## 9. References

- Cunkasl M, Aydogdu O. Realization of fuzzy logic controlled brushless DC motor drives using Matlab/Simulink. *Mathematical and Computational Applications*. 2010; 15(2):218–29.
- Yedamale P. Brush Less DC (BLDC) Motor Fundamentals. Chandler, AZ: Microchip Technology, Inc., last access. 2015. Available from: [http://ww1.microchip.com/downloads/en/Market\\_Communication/Feb%202009%20microSOLUTIONS.pdf](http://ww1.microchip.com/downloads/en/Market_Communication/Feb%202009%20microSOLUTIONS.pdf)
- Lee BK, Ehsani M. Advanced simulation model for brushless DC motor drives. *Electric Power Components and Systems*. 2003; 31(9):841–68.
- Hong W, Lee W, Lee BK. Dynamic simulation of brushless DC motor drives considering phase commutation for automotive applications. *Electric Machines & Drives Conference, IEMDC'07*; 2007.
- Akkaya R, Kulaksız AA, Aydogdu O. DSP implementation of a PV system with GA-MLP-NN based MPPT controller supplying BLDC motor drive. *Energy Conv and Management*. 2007; 48(1):210–8.
- Pillay P, Krishnan R. Modeling, simulation and analysis of permanent-magnet motor drives. Part II: The brushless DC motor drive. *IEEE Trans on Industry Applications*. 1989; 25(2):274–9.
- Carlson R, Lajoie-Mazenc M, Fagundes CDS. Analysis of torque ripples due to phase commutation in brushless DC machines. *IEEE Trans on Industry Applications*. 1992; 28(1):632–8.
- Safi SK, Acarnley PP, Jack AG. Analysis and simulation of the high-speed torque performance of brushless DC motor drives. *Proceedings of the IEE*; 1995. p. 191–200.
- Figueroa J, Brocart C, Cros J, Viarouge P. Simplified simulation methods for polyphase brushless DC motors. *Mathematics and Computers in Simulation*. 2003; 63(3-5):209–24.
- Hung CW, Lin CT, Liu CW. An efficient simulation technique for the variable sampling effect of BLDC motor applications. *IECON*; 2007. p. 1175–9.
- Devi RM. Variable sampling effect for BLDC motors using fuzzy PI controller. *Indian Journal of Science and Technology*. 2015 Dec; 8(35):1–5.
- Ramesh V, Latha YK. PFC-based control strategies for four switch VSI fed BLDC motor. *Indian Journal of Science and Technology*. 2015 Jul; 8(16):1–6.

13. Sankar AB, Seyezhai R. Development of active neutral point clamped multilevel inverter fed BLDC drive employing FPGA. *Indian Journal of Science and Technology*. 2015 Feb; 8(4):1–8.
14. Neethu K, Boopathi M, Mannayee G, Kanish TC. Fuzzy logic based speed control of BLDC motor on sensorless technique for space applications. *Indian Journal of Science and Technology*. 2016 Jul; 9(27):1–9.
15. Raeisi N, Meymand AM, Akbarizadeh G. Scour depth prediction in sand beds using artificial neural networks and ANFIS methods. *Indian Journal of Science and Technology*. 2015 Aug; 8(18):1–9.
16. Rezvani A, Izadbakhsh M, Gandomkar M, Vafaei S. Implementing GA-ANFIS for maximum power point tracking in PV system. *Indian Journal of Science and Technology*. 2015 May; 8(10):1–10.
17. Srikanth D, Rao R, Vidyullatha P. Comparative analysis of ANFIS, ARIMA and polynomial curve fitting for weather forecasting. *Indian Journal of Science and Technology*. 2016 Apr; 9(15):1–6.