

Blockage Detection in Seeder

Shefali Malhotra*, Surabhi Bhosale, Prachi Joshi and B. Karthikeyan

School of Electronics Engineering (SENSE)
Vellore Institute of Technology, Vellore - 632014, Tamil Nadu, India; shefali.malhotra91@gmail.com,
bhosalesurabhi@gmail.com, psjrprachi@gmail.com

Abstract

Objective: To detect blockages in the seed tube using an ultrasonic sensor and reporting the same to a smartphone application. **Methods/Analysis:** Seeder machines in agricultural operations may face real-time problems of plugging due to stubble, stones or unusually large seeds. The ultrasonic sensor transmits sound waves and uses delay in the received echo signal to measure distance from the sensor to the obstacle (either the flowing seed or the opposite wall of the nozzle). Based on the calculated distance, the flow of seeds through the nozzle can be detected. **Findings:** At present, a person is employed in the field to look after the seeder machines and detect the blockages, making it more prone to human errors. Thus it is necessary to find an automated and productive solution to detect the blockages in seeder. The proposed solution monitors and report blockages in the nozzles of agricultural seeder machines by using low cost ultrasonic sensors. One such sensor will be placed on each row unit and all these sensors will continuously communicate with a central controller placed on the seeder. The sensors will report nozzle-blockage to the controller and which will then immediately notify the same to the smartphone user via a graphical real-time application. All kinds of blockages such as stones, stubble, unusually large seeds can be detected by this mechanism. These blockages will be reported to the user via a smartphone application (based on GSM) and the exact location of the blockage will be intimated to the user. Looking at the application window, the user will get real-time information about the blocked nozzle in the seeder. **Applications/Improvements:** The solution offered in this paper can further be improved by using other wireless technologies such as Wi-Fi (instead of GSM used here).

Keywords: GSM Module, Microcontroller, Smartphone Application, Seeder Nozzle, Ultrasonic Distance Sensor

1. Introduction

India, the seventh largest country in the world in terms of area¹ is primarily an agrarian economy. Because of its diverse topography and climates, different varieties of crops can be grown in India. A study in 2011 revealed that the agricultural sector in India contributes to 18.5 percent of the economy, supports about 15 percent of the total exports and approximately two-thirds of the workforce. Hence, efforts are undertaken to increase the agricultural productivity of the nation using agricultural engineering techniques. Usually, agricultural combines include a harvesting apparatus, an infeed mechanism, a separating apparatus and a cleaning apparatus². Hardware, for example, seeder machines, are progressively being utilized as a part of India, for quick and effective seeding systems. An overview in 2010 puts the agrarian hardware

market in India at 299.1 billion rupees and expects quick development of this industry³. John Deere, a Fortune 500 company, has successfully expanded its agricultural machinery market in India⁴. Seeder machines are being utilized progressively as a part of India Seeding device for use regarding tractor drawn seeding gear, especially reforesting hardware, containing a slanted tubular part having one end essentially associated with a thatching gadget or comparative soil-breaking gadget at a lifted separation over the ground in order to yield return capably against torque in vertical and flat heading⁵. A mechanical assembly to dispense particles incorporates a capacity tank for containing particles to be administered a mechanism for transferring particles from the Storage tank and an air conveyance framework for accepting particles from the metering instrument⁶. Such seeder machines face a significant problem of plugging in the

*Author for correspondence

nozzles due to lumps, stubble, stones and irregular seed sizes. It is important for the seeding equipment operator to be able to detect that a continuous flow of seeds progresses down each seed tube, since the seed tubes can sometimes become blocked, or a bin can become empty⁷. When these circumstances arise, seed flow stops and areas of the field remain unplanted, reducing the efficiency of utilization of the field. Agricultural seeder manufacturers today are focused on improving seed singulation and planting speed. But, increasing the seeder speed increases the possibility of blockages in the seeder nozzles.

Traditional approaches often use expensive, invasive sensors from concern that inexpensive, non-invasive sensors will incur many false positives⁸. High sensor cost leaves many numerous lower quality destinations with scanty automation and no sensing⁸. A particle blockage monitoring system utilizes an adaptable, piezoelectric molecule sensor component in a portion of a particle flow path so that various particles going in the molecule stream way strike the adaptable molecule sensor while avoiding harm to the particles and keeping up the forward energy of the considerable number of particles in the particle stream way⁹. Computer implemented methods for deciding blocked and incompletely blocked conditions in the flow of particulate matter in an agrarian air seeding framework are unveiled which consequently adjust for changes in seed sort, seed density, fan rate or seed rate¹⁰. System frequency response is one of the approaches used for partial blockage detection¹¹. A partial blockage increases the amplitude of the pressure oscillations at even harmonics. Such an increase in amplitude has an oscillatory pattern, the frequency and amplitude of which may be utilized to anticipate the location and size of a partial blockage¹¹. Various types of detecting systems have been used in the past, including some with air pressure switches such as shown in U.S. Pat. Nos. 3,863,428¹² and 4,286,424¹³, flow sensors as show in U.S. Pat. Nos. 4,463,345¹⁴, acoustic Sensors in U.S. Pat. Nos. 4,961,304¹⁵. However, in certain situations such as where the plugging occurs near the discharge structure ahead of the pressure switch, the switch will not function to provide the necessary warning signal to the operator. Therefore, systems with pressure sensors often let certain types of blockages go undetected¹⁶.

There are several ways to measure distance without contact example Time of flight, Triangulation, Vision based method etc. One way is to use ultrasonic waves for distance measurement. Ultrasonic sensor level measurements are

based on the determination of the time-of-flight (ToF)¹⁷. Ultrasonic transducers measure the amount of time taken for a pulse of sound to travel to a specific surface and return as the reflected echo¹⁸. The accuracy of the TOF can be enhanced by adopting simple interpolation algorithms in conjunction with the Wavelet Transform (WT) technique¹⁹. Digital signal processing strategies are developed in order to extract the valuable data from the samples acquired from the received wave²⁰. A distance measurement system using an ultrasonic transducer is based on comparison of the unknown distance with a standard length in the same medium. The measurement made is independent of temperature, humidity, pressure, and any other atmospheric conditions. The proposed method claims improved performance and accuracy over the methods known so far²¹. There are three advantages: (1) the ultrasonic signal loss is much less, (2) the location of the transducers is well defined, and (3) the phase and pulse shapes are controlled and reproducible²². Modern microcontroller and wireless sensor can provide a range of solutions for the automated monitoring of water levels in many applications²³.

At present, a person is employed in the field to look after the seeder machines and detect the blockages, making it more prone to human errors. Thus it is necessary to find an automated and productive solution to detect the blockages in seeder. This paper aims at creating a solution to monitor and report blockages in the nozzles of agricultural seeder machines by using low cost ultrasonic sensors. Ultrasonic sensors is most significant among all²⁴. All kinds of blockages such as stones, stubble, unusually large seeds can be detected by this mechanism. These blockages will be reported to the user via a smartphone application (based on GSM) and the exact location of the blockage will be intimated to the user.

This paper presents a low cost design and development of the sensor system to detect and report blockages in seeder Nozzles. It is organized as follows: Section II defines the problem and Section III provides the proposed solution. The complete system with the help of a block diagram and various components involved is described in the Section IV and V. Results and observation are provided in Section VI. Finally Section VII concludes the paper.

2. Problem Definition

To design an embedded system to monitor and produce solutions to detect the blockages in agricultural seeder

machines by using low cost ultrasonic sensors and happening of blockages with its location should be reported to the user via a smartphone application.

3. Proposed Solution

Huge agricultural seeder machines have multiple row units for parallel sowing of seeds. Our proposed solution consists of the following features:

1. One pair of ultrasonic distance sensors (transmitter and receiver) will be required for each row unit. These sensors will be mounted on the inner side of the seeder nozzles.
2. They will detect blockage based on the distance measured by them at periodic intervals.
3. Every seeder machine will require one central microcontroller that communicates with all the sensors on all the row units.
4. It obtains the sensor outputs and displays the same on the LCD display as well as sends them immediately to the user's smartphone application via GSM.
5. Hence, the user will receive a notification on his smartphone every time a blockage is detected on any of the row units. He will know the exact location of the blockage so that he can take corrective action immediately.

4. Hardware System Design

Based on the proposed solution mentioned before, the general block diagram is shown in [Figure 1]. It is simple and self-explanatory.

4.1 Sensor

In the work, the HC-SR04 ultrasonic distance sensor shown in [Figure 2] is used because of its easy availabil-

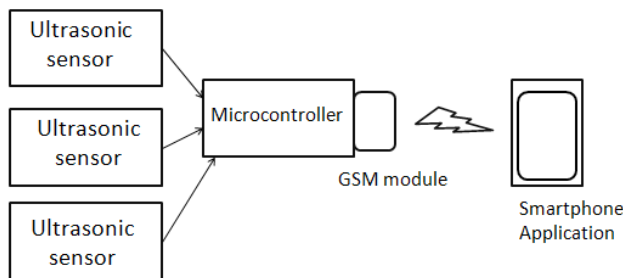

Figure 1. Block Diagram.

ity, low cost and suitable range of operation. HC-SR04 is a ranging module which provides a non-contact measurement function in the range 2 to 400 cm. Its working frequency is 40 kHz.

The working of the sensor can be shown in [Figure 3]. A 10us trigger pulse starts the ranging process of the sensor. The Module sends out an 8 cycle burst of ultrasound at 40 kHz and raises its echo. The echo signal is a distance object proportional to the pulse width and the range. The time interval between sending the trigger signal and receiving the echo signal gives the range of the object.

$$range = \frac{t_h * v}{2} \tag{1}$$

Where,

t_h is high level time and v is the velocity of sound (340 m/s)

4.2 Microcontroller

The ARM Cortex M0 series microcontroller is used for the processing. The connections to the microcontroller can be seen in [Figure 4]. The sensors are connected to the



Figure 2. HC-SR04 Ultrasonic Sensor.

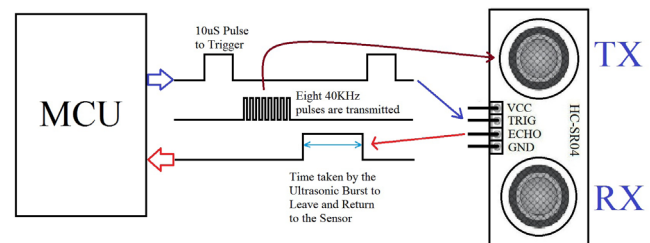

Figure 3. Working of HC-SR04 sensor.

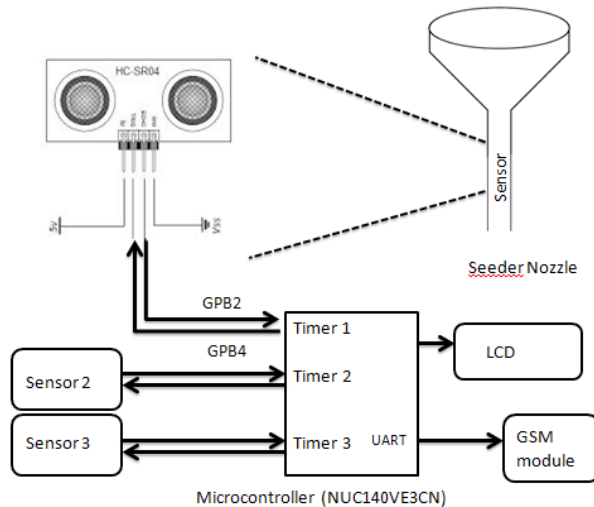

Figure 4. Connections to the microcontroller.

timer pins of the microcontroller. The timer interrupts are used to measure the distance output of each sensor. The nuvoton has an extra feature of timer controller which generates the interrupt at the timeout and provide us the value of current operation. This timer feature is used in this paper to calculate the distance of the object. The timer works in three modes one shot mode, Toggle mode and Periodic mode. In this paper, one shot feature of the timer is considered in which as the timer is triggered it starts counting and compares the count with the value stored in compare register and once the count reaches that value it generates the interrupt and rest the count to initial value. An LCD interfaced with the microcontroller displays the distances measured by all the sensors. If two consecutive distances measured by a sensor are equal to the total width of the nozzle, we may conclude that the nozzle is blocked. This blockage message is displayed on the LCD screen. A GSM module is interfaced with the microcontroller which immediately sends an SMS to the user's smartphone. The user can then view the exact location of the blockage on his application.

4.3 GSM Module

The GSM modem which acts as a mobile phone accepts any GSM network operator SIM card with its own unique phone number [25]. The GSM module SIM 300 is interfaced with NUC140 through serial ports of the controller. The AT commands such as 1. AT- to check proper functioning of GSM modem, 2. AT+CMGF=1, to activate the text mode, 3. AT+CMGS= "Mobile Number", to send mes-

sage to the mentioned number followed by the <message contents> are send through the serial port to configure GSM modem.

Once the blockage is detected in any of the Seeder's Nozzle a text message is send to the user intimating him about the blockage. A message is send only once if continuously blockage is detected in the same nozzle.

5. Software Design

Software design is an integral part of this paper. Once the blockage is detected in any of the Seeder's Nozzle a text message is send to the user intimating him about the blockage. A message is send only once if continuously blockage is detected in the same nozzle. Following algorithm describes the software design of the system in brief.

Algorithm

1. Trigger ON the sensor
2. Calculate distance travelled by the wave
3. If calculated distance = diameter of nozzle
 - Blow Buzzer;
 - Send AT commands to GSM module;
 - Notify user on Mobile app;

6. Results and Observations

Case 1: Blockage in single nozzle

A notification arrives in the Android application intimating the user about the blockage.

Case 2: Simultaneous blockages in multiple nozzles

When blockages occur simultaneously in multiple nozzles, the blockage that is detected first is reported through the application.

Note:

- If blockage is detected in one nozzle, it notifies only once, irrespective of the time taken to clear the blockage. This minimizes the wireless communication cost.
- If the blockage in a nozzle is cleared, and if a new blockage is detected later in the same nozzle, then the new blockage is notified.

7. Conclusion

Engineering technologies are increasingly being used in large agricultural farms so that productivity on the farm is increased. Huge seeder machines are being used in India as

well as other parts of the world, which focus on optimum seed singulation and seed placement. Such machines face the problem of blockages in their nozzles due to a variety of reasons. Blockage in one nozzle significantly affects the efficiency of the seeding process. Also, if the farm owner is not notified at real time about the blockage, productivity further decreases.

This paper successfully offers a low-cost solution for monitoring and detecting blockages in the seeder nozzles. It also integrates wireless connectivity for intimating users in real time about blockages in seeders. This concept can be implemented in agricultural seeder machinery so that timely action can be taken in case of blockages so that productivity of sowing seeds is not hampered.

The solution offered in this paper can further be improved by using other wireless technologies such as Wi-Fi (instead of GSM used here). Different microcontrollers may be used and tested for the same functionality and then a suitable microcontroller can be chosen on the basis of cost and speed.

8. Acknowledgment

The overall progress of a project depends on the support and guidance of many people involved in its success. Beginning from the selection of our project topic to its final implementation, our project guide and mentor, Prof. B. Karthikeyan, has been extremely supportive and motivating. We would like to thank Prof. Gerardine I. Mary and all the faculty members in the Embedded Systems division for their co-operation. Finally, we would like to extend our gratitude towards our family and friends for their support and encouragement.

9. References

- MBA club India, Countries of the World - Area Wise in Km Miles Available from: <http://www.mbaclubindia.com/forum/countries-of-the-world-area-wise-in-km-miles-5585.asp#.VTFHbPmUffg> Accessed on 02/2015.
- Smith DB. System and method for detecting a condition indicative of plugging of a discharge path of an agricultural combine. 2008 Jun.
- Manchikanti P, Sengupta M. Agricultural machinery in India: IPR perspective. *Journal of Intellectual Property Rights*. 2011 Mar; 16:163–9.
- Article title. Available from: https://en.wikipedia.org/wiki/John_Deere, Accessed: 02/2015.
- Mickelsson S-M, Sture R. Hall Tractor-drawn seeding apparatus. 1981 Mar.
- Memory RJ, Benneweis RK, Klassen ND, Wilson RJ, Wilson JN. Apparatus for controlling the flow rate of an air seeder. 2001 Feb.
- Robar, James DJ. Grain sensor. 1984 Apr.
- Zhang C, Heidemann JS. Accurate Pipeline Blockage Detection with Low-Cost Multi-modal Sensing. 2014 IEEE 11th International Conference on Mobile Ad Hoc and Sensor Systems (MASS). 2014 Oct. p. 172–80.
- Thomas JC. Air seeder blockage monitoring system. 1998 Nov.
- Fuss Trevor D, Bramel PR, Wanner JJ. Adaptive methods of determining blockage in an air seeder blockage monitoring system. 1999 Jul.
- Sattar AM, Hanif Chaudhry M, Kassem AA. Partial blockage detection in pipelines by frequency response method. *Journal of Hydraulic Engineering*. 2008 Jan; 134(1):76–89.
- Baxter Robert L. Blockage monitor for a cotton picking machine. 1975 Feb.
- Fox RE, Phelan JJ. Deere Company Blockage detector for a cotton harvester. 1981 Sep.
- Okkerse SWJH, Friesen RJ, Robar JDJ. Seed flow monitor. 1984 Jul.
- Ovsborn JH, Hahn RW. Cotton flow monitoring system for a cotton harvester. 1990 Oct.
- Fox RE, James JP. Cotton harvester blockage detection method and flow sensor therefor. 1991 Nov.
- Carullo A, Parvis M. An ultrasonic sensor for distance measurement in automotive applications, *Sensors Journal, IEEE*. 2001 Aug; 1(2):143–7.
- Dewangan V, Dewangan B, Verma A. Development of an Embedded System for Distance Measuring Using Ultrasonic Sensor. *International Journal of Science and Research*. 2013; 1–4.
- Andria G, Attivissimo F, Lanzolla A. Digital measuring techniques for high accuracy ultrasonic sensor application. *Instrumentation and Measurement Technology Conference, 1998. IMTC/98. Conference Proceedings. IEEE*. 1998 May 2. p. 1056–61.
- Gueuning F. Accurate distance measurement by an autonomous ultrasonic system combining time-of-flight and phase-shift methods. *Instrumentation and Measurement Technology Conference, 1996. IMTC-96. Conference Proceedings. Quality Measurements: The Indispensable Bridge between Theory and Reality, IEEE*. 1996; 1:399–404.
- Chande PK, Sharma PC. A Fully Compensated Digital Ultrasonic Sensor for Distance Measurement. *IEEE Instrumentation and Measurement*. 1984 Jun; 33(2):128–9.

22. Wobschall D, Zeng M, Srinivasaraghavan B. An Ultrasonic/Optical Pulse Sensor for Precise Distance Measurements. Sensors for Industry Conference. 2005 Feb. p. 31–4.
23. Ahmed N. Use of Wireless Sensor and Microcontroller to Develop Water-level Monitoring System. Indian Journal of Science and Technology. 2014 Sep; 7(9):1321–6.
24. Bhardwaj S, Warbhe A, Kumar BR. Sensor System Implementation for Unmanned Aerial Vehicles. Indian Journal of Science and Technology. 2015 Jan; 8(S2):7–11.
25. Dhananjeyan S, Mohana Sundaram K, Kalaiyarasi A, Kuppusamy PG. Design and Development of Blind Navigation System using GSM and RFID Technology. Indian Journal of Science and Technology. 2016 Jan; 9(2):1–5.