

Z-Wave based Zoning Sensor for Smart Thermostats

S. Rohini* and K. Venkatasubramanian

School of Electronics, VIT University, Chennai - 600127, Tamil Nadu, India;
rohini.s2013@vit.ac.in, venkatasubramanian.k@vit.ac.in

Abstract

Background/Objectives: This paper speaks about the design of a wireless sensor module that senses the temperature and humidity of a residential building. In most of the cases the temperature in a home is controlled by a single thermostat placed at a central location. **Methods/Statistical Analysis:** Few rooms might be hotter or cooler than the other. Hence, zoning systems are used to provide independent comfort for each zone. Each zone can have a sensor that detects the temperature and humidity of the zone. But, the current thermostats have a sensor onboard which detect temperature and humidity. **Findings:** This sensor output can be affected by the heat produced by other devices on the thermostat. The solution of this problem is a wireless sensor which detects the exact temperature of the zone. Based on these values the thermostat runs a predefined algorithm and maintains the required environment in each zone. On comparison with different wireless technologies like Zigbee, Wi-Fi, Bluetooth. Z-wave suits more for the above applications whose frequency is 900 MHz which is different from the crowded 2.4 GHz frequency band and Z-wave also has a higher range and battery life. This system has a wireless sensor module which talks to the thermostat using Z-wave wireless communication protocol. This system uses ARM based microcontroller for wireless sensor unit. The thermostat has a high end ARM based microprocessor and a display unit which shows the acquired temperature and humidity. **Conclusion/Improvements:** his design shows a wireless sensor module that is implemented for a single zone system. Improvement can be done on the design to develop a low power battery operated sensor module that can be implemented for a multi zone system.

Keywords: Control System, Heating, Thermostat, Ventilating and Air Conditioning (HVAC), Wireless Communication Protocol, Zoning

1. Introduction

Heating, Ventilation and Cooling (HVAC) is the single biggest cause to a home's energy bills and carbon outflows, representing 43% of private energy utilization in the U.S. furthermore, 61% in Canada and the U.K., which have colder atmospheres¹. Studies have demonstrated that 20-30 % of this energy could be spared by stopping the HVAC system when occupants are resting or away. A 20-30% lessening in HVAC energy would mean funds of about \$15 every month for the normal family in the U.S. For some individuals, this little money related sparing does not legitimize the troubles of streamlining HVAC operation on a consistent schedule. At the national scale², on the other hand, these same investment funds mean more than 100 Billion kWh at an expense of roughly \$15

billion every year, and would forestall roughly 1.12 billion tons of contaminations from being discharged into the air every year. It is an exemplary disaster of the center. To address this circumstance, another arrangement must be made that "just works" and spares energy without needing every day thought or activity by family members. An answer for this issue are the smart thermostats³ ⁴ that uses inbuilt sensors to naturally stop the HVAC framework when the tenants are dozing or away from home. The basic function for the thermostat is to set the temperature and control the HVAC system to maintain the current temperature to reach the set temperature. A second and expanding role is to spare energy. Numerous new highlights and capacities have risen in the previous a quarter century encourage the energy saving. The most propelled thermostat control various zones and humidity

* Author for correspondence

levels. Still different highlights incorporate one-touch energy-savings, diagnostics, access to weather, alerts for maintenance and display of energy consumption. Remote control is turning into a famous highlight as advanced mobile phones and Internet access. Expanded comfort is achieved by having the limit of the HVAC framework⁵ (cooling or warming conveyed) take after the shift in burden as it changes over the house. For instance, it is regular for two-stored homes to be excessively hot on the second floor in both summer and winter. Zoning has the capacity of occupying a greater amount of the HVAC ability to the territory with the higher burden⁶. Another regular case is a home with a note worthy zone of west-bound and east-bound windows. In the late spring, the east rooms overheat in the morning and the west rooms overheat toward the evening.



Figure 1. Zoning system.

The Figure 1 shows the design of a home with zoning system incorporated in it. In this paper, we deal with a wireless sensor that detects the temperature of each zone separately. The communication protocol used is Z-wave.

Z-Wave^{7,8} conveys using a low-power wireless technology planned particularly for remote control applications. It is enhanced for low-latency, reliable communication with information rates up to 100kbit/s, dissimilar to Wi-Fi and other IEEE 802.11-based remote LAN frameworks that are outlined essentially for high-data transfer capacity information stream. Z-Wave works in the sub-gigahertz frequency range, around 900 MHz. This band rivals some cordless phones and other shopper gadgets, yet stays away from impedance with Wi-Fi, Bluetooth and different systems that work on the 2.4 GHz band. Z-Wave^{9,10} is intended to be effectively retrofitted in buyer hardware items, including battery worked devices, for example, remote controls, security sensors and smoke alarms.

Starting 2014, Z-Wave is bolstered by more than 250 makers overall and shows up in an expansive scope of consumer and business items in the US, Europe and Asia. The lower layers, MAC and PHY, are portrayed by ITU-T G.9959 and completely in reverse perfect. The Z-Wave handset chips are supplied by Sigma Designs and Mitsumi. Below are the few of the advantages of Z-wave:

- secure and reliable communication
- low power utilization
- simple installation
- local or remote control
- various accessible devices, interoperability

The Figure 2 shows the applications of the Z-wave wireless network



Figure 2. Z-wave network.

2. Research Method

The Figure 3 shows the wireless sensor unit and the Figure 4 shows the complete design of the controller unit. The wireless sensor unit contains the sensor, the microcontroller unit and the Z-wave device. The controller unit contains the Z-wave device, microcontroller, display unit and the HVAC unit. In the wireless sensor unit, the sensor is RHT03 which is a humidity and temperature sensor. It communicates using Max detect 1-wire bus protocol.

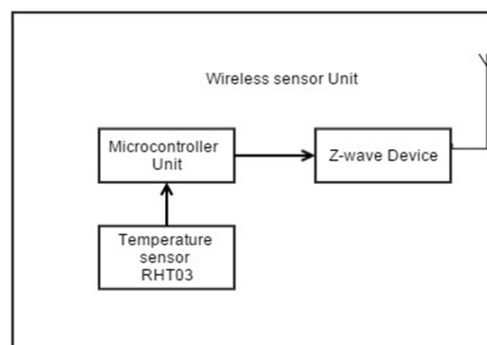

Figure 3. Block diagram of the wireless sensor unit.

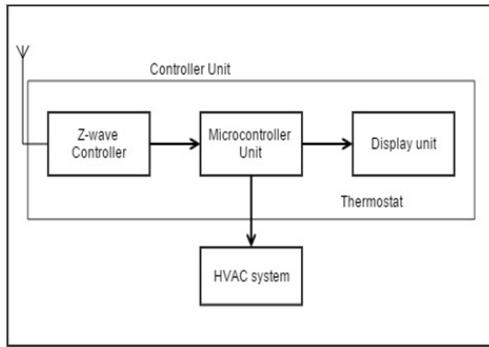

Figure 4. Block diagram of the controller unit.

The microcontroller has a free RTOS which has tasks that receives data from the sensor every 30 sec and the sends the information to the Z-wave device. The microcontroller communicates to the Z-wave device using UART or USB. The Z-wave device then sends the information to the controller in whose network it exists. Z-wave controller sends the information sent by the controller to the microcontroller unit using UART or USB in the controller unit. The microcontroller based on the temperature value takes decision to control the HVAC system to maintain the desired set point. The microcontroller also sends information to display it on the display unit.

2.1 Sensor

RHT03¹¹ is a temperature and relative humidity measurement sensor. It has high precision, capacitive type, calibrated digital signal output. It is a small size, low power, long term stable and has long transmission distance up to 100m. The calibration coefficients are stored in the OTP memory, which are used every time a sensor values is used. The Table 1 shows the pin details of the sensor RHT03.

Table 1. Pin details of RHT03

Pin	Name	Comment
1	VDD	Supply voltage
2	DATA	Signal
3	NULL	Not Connected
4	GND	Ground

2.1.1 Pins and Power (VDD)

The supply voltage to the sensor is 3.6-6 V. It is expected to put a coupling capacitor of 100nF between the supply pins and the ground as shown in Figure 5.

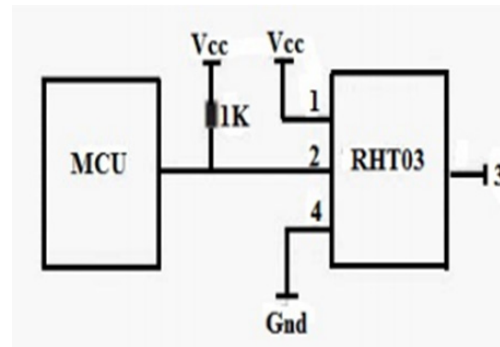

Figure 5. Pin diagram of RHT03.

Signal and communication: For the communication between the sensor and the microcontroller MaxDetect-1 wire bus. The communication between the sensor and the microcontroller starts with a start signal, which is a transition from high to low signal. After this the microcontroller pulls the line high waiting for the sensor to respond. The response is sent from the sensor by pulling the line low and the sensor gets ready to send the 40 bit values. The 40 bit value has the relative humidity, temperature and the check sum.

The first 16 bit of the 40 bit has the relative humidity which is again divided into 8 bit of integral RH data and 8 bit of decimal RH data. The next 16 bits of the 40 bit data is the temperature value which is again divided into 8 bit of integral temperature data and 8 bit of decimal temperature data. The next 8 bit of the 40 bit is the checksum value which is the sum of all the 32 bits that are sent before. The time interval of the whole process must be more than 2 seconds.

2.1.2 MaxDetect 1-wire Bus

Data is comprised of integral and decimal part; the following is the formula for data.

The data that is received consists of the decimal part and the integral part. Below is the formula that shows how the data is divided

DATA = 8 bit integral Relative humidity data+8 bit decimal Relative humidity data+8 bit integral Temperature data+8 bit decimal Temperature data+8 bit check

The check sum is calculated as

Check sum = 8 bit integral Relative humidity data+8 bit decimal Relative humidity data+8 bit integral Temperature data+8 bit decimal Temperature data

If the transmission is right then the received checksum and the calculated check sum after reception of all the bits should be correct.

Example: Microcontroller Unit has received 40 bits data from sensor RHT03 as

0000 0001 0111 11100000 0000 0001 10011001 1000

RH data T data Check Sum

Check sum = 0000 0001+0111 1110+0000 0000+0001 1001 = 10011000

RH = (0000 0001 0111 1110)/10 = 38.2%RH

T = (0000 0000 0001 1001)/10 = 25°C

When MSB of temperature is 1, it means the temperature is below 0 degree Celsius.

Example: 1000 0000 0110 0101, T = minus 10.1°C.

The sensing element in the sensor is a polymer humidity capacitor. Its operation range of the sensor for humidity is from 0-100 % RH and for the temperature is -40 to 80 °Celsius. The sensitivity of the sensor is 0.1% RH for humidity and 0.1°C for the temperature.

2.2 Host Microcontroller unit

The LPC1115 LPCXpresso¹² board with NXP's ARM Cortex-M0 microcontroller has been intended to make it as simple as could reasonably be expected to begin with Cortex-M0. The LPCXpresso embodies a target board joined with a JTAG debugger. The LPC1115 has 8 kB SRAM, 64 kB Flash, SSP, I2C, UART, ADC and so on. The Figure 6 shows the LPC1115 LPCXpresso board.

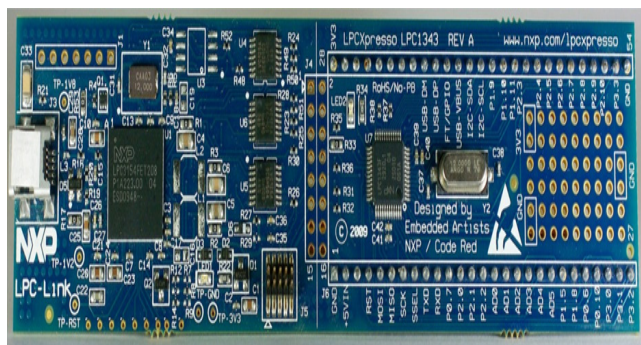

Figure 6. LPC1115 LPCXpresso board.

The microcontroller receives the temperature value and sends it to the z-wave device using UART or USB. On the implementation there are different tasks which used for the proper functioning of the device. One task performs the job of receiving the data from the sensor. The other task performs sending the data to the Z-wave device and waiting for the data that can be received from the z-wave device. Semaphores are used for data synchronization. Inter process communication happens through message

queues. The data from the microcontroller to the Z-wave device is sent in a specific format as per the serial API.

2.3 Z-wave

Z-wave microcontroller¹³ is constructed around an upgraded 8051 microcontroller center that runs off a 32MHz external oscillator. (The inner framework clock is 16MHz). The RF a piece of the chip contains a FSK handset for a 908.42MHz or 868.42MHz recurrence that is programming selectable. The advanced piece of the IC comprises of 32KB of FLASH memory, 2KB of SRAM and a modest bunch of control-driven peripherals. With force supply somewhere around 2.2 and 3.6 volts, it expends 23mA in transmit mode (about -5dBm) and 21mA and 3A separately in get and profound slumber modes. MCU peripherals comprise of standard modules like SPI, clocks, UART, External interrupt and brownout recognition and in addition particular modules for control applications: 12-bit ADC (simple to computerized converter) and upgraded TRIAC control with zero intersection identification line. Ten GPIO lines are multiplexed with other I/O capacities.

The Z-wave micro communicates with the host microcontroller using UART or USB. The device is then sent to the Z-wave controller using the appropriate command classes. The device has to be configured as a routing multilevel sensor device class. Based on the command classes sent the controller sends it to the microcontroller to which it is connected to. Before sending the values the device has to get included to the network with proper inclusion process and to remove the device from the network proper exclusion process should happen.

2.4 Microcontroller and Display Unit

An ARM based microcontroller is used at the controller. It provides low-power solutions for applications demanding high-performance multimedia and graphics. It can be interfaced through I2C, UART, CAN and USB. The display contains TFT color display, together with a PCAP touch panel on top provides the main user interface. It runs on a Linux platform.

This microcontroller has pthreads implemented which runs parallel to take care of all the functions of the microcontroller. The microcontroller receives the sensor value from the Z-wave controller using UART or USB. There are different pthreads which works to display

the temperature and humidity on the home screen of the thermostat. Based on the values that are set on the thermostat and the current values from the sensor the necessary actions will be taken to control the HVAC system. The actions will be turning on/off the heating or the cooling system of the particular zone. The Zone can be associated to the Z-wave device with the Node ID. Every time a device gets added to the network a node ID is assigned to it by the controller which is used for this association.

The temperature and humidity values are displayed on the display unit. The microcontroller talk to the application is a predefined data exchange format. The connection between the microcontroller and the application is through Socket connection.

3. Results

The Figure 7 below shows the humidity value that is read from the sensor to the microcontroller. It shows that the received humidity value is 38% RH. Similarly the Figure 8 shows the temperature value that is read which is 25°C.

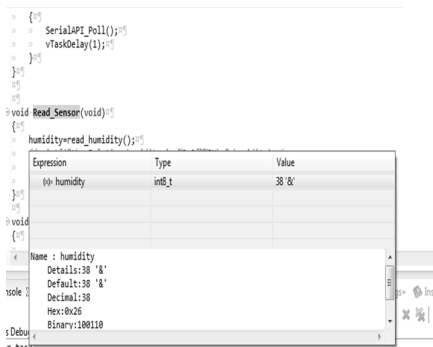

Figure 7. Screenshot humidity value.

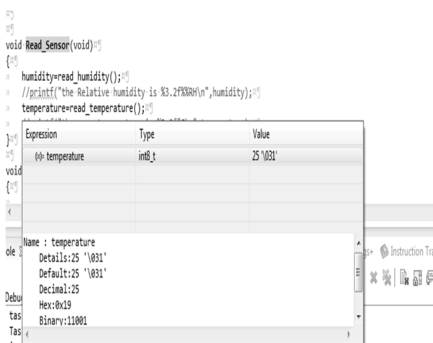

Figure 8. Screen shot of temperature value in °C.

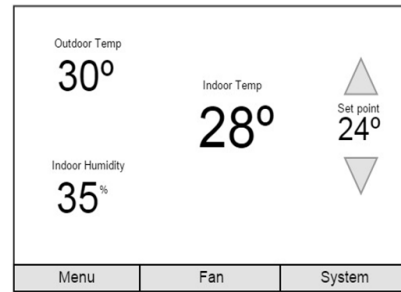

Figure 9. Display of the indoor temperature and humidity values on the Screen using on board sensor.

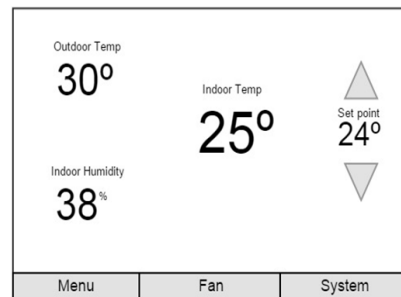

Figure 10. Display of the indoor temperature and humidity values on the Screen using wireless sensor.

The Figure 9 and 10 shows the temperature and the humidity difference from the on board sensor and the Z-wave sensor. It is observed that the Z-wave sensor output is more accurate.

As per the work in the paper by Bassam Shaer¹, the Zigbee based wireless sensor had a few drawbacks like the increase in cost because of the use of ADC and also the range of 100 ft. was not achieved in reality. Seeing these parameters Z-wave can be a possible solution for the design of a wireless sensor that can be associated to each zone in the Zoning system. Since Z-wave has a lesser frequency than Zigbee it can achieve higher range than Zigbee. Below are the few parameters which show that Z-wave is better than Zigbee for this application. The Table 2 shown below shows a comparison between the two wireless technologies Z-wave and Zigbee.

Table 2. Comparison table

Parameter	Zigbee	Z-wave
Frequency	2.4 Ghz	900Mhz
Range	10m	30m
Battery life	100+ days	100+ days
Network size	65536	232
Data rate	250 kbits/sec	100kbits/sec

4. Conclusion

In this research work, the wireless sensor for a single zone is implemented. The controller can have a network size of 232. Hence, many wireless sensors can be added to the networks which are associated with different zones. The sensor reports the temperature and humidity value every 30 sec. The power consumption can be reduced by decreasing the time interval or sending only when value changes and put the device to sleep when it is not processing. Since the Z-wave devices can achieve 4 hops, greater range can be obtained by having a repeater in the network. This works provides solution to avoid the hard wires to install sensors in zoning system and it also proves a possible solution for the inaccuracy in the temperature and humidity values that are detected by the onboard sensors.

5. Acknowledgement

This research was done at the premises of Ingersoll Rand Technology services Pvt. Ltd, Chennai. I would like to extend my heartfelt thanks to Ingersoll Rand and its employees for providing me with the opportunity and all the support to complete this research successfully.

6. References

1. Shaer B, Wadsworth DM. Design of an HVAC Zone Control System and Embedded Microcontrollers. *GSTF International Journal of Engineering Technology (JET)*. 2012; 1(1):7–12.
2. Nassif N, Kajl S, Sabourin R. Optimization of HVAC control system strategy using two-objective genetic algorithm. *International Journal of HVAC and R Research*. 2005 Jul; 11(3):459–86.
3. Peffer T, Pritoni M, Meier A, Aragon C, Perry D. How people use thermostats in homes: a review. *Building and Environment*. 2011 Dec; 46(12):2529–41.
4. Lu J, Sookoor T, Srinivasan V, et al. The smart thermostat: using occupancy sensors to save energy in homes. 2010; 3–5.
5. Sookoor T, Holben B, Whitehouse K. Feasibility of retrofitting centralized HVAC systems for room-level zoning. *IEEE Transactions*. 2013 Apr; 8–11.
6. Saha A, Kuzlu M, Pipattanasomporn M. Demonstration of a home energy management system with smart thermostat control. *IEEE Transactions*; Washington, Dc. 2013 Feb 24-27. p. 1-8.
7. Ferrari G, Medagliani P, Di Piazza S, Martalo M. Wireless sensor networks: performance analysis in indoor scenarios. *EURASIP Journal on Wireless Communications and Networking*. 2007.
8. Robles RJ, Kim T-H. A review on security in smart home development. *International Journal of Advanced Science and Technology*. 2010 Feb; 15:13–22.
9. Spadacini M, Savazzi S, Nicoli M. Wireless home automation networks for indoor surveillance: technologies and experiments. *EURASIP Journal on Wireless Communications and Networking*. 2014 Jan; 6: 1–17.
10. Tuna G, Cagri Gungor V, Gulez K. Wireless sensor networks for smart grid applications: a case study on link reliability and node lifetime evaluations in power distribution systems. *International Journal of Distributed Sensor Networks*. 2013 Jan.
11. Digital relative humidity and temperature sensor RHT03. Datasheet Sensor RHT03.
12. LPC1110/11/12/13/14/15. Datasheet lpc1115. 2014.
13. Z-Wave. 2015. Available from: <http://en.wikipedia.org/wiki/Z-Wave>